

## SAxx20M-10MP

### 4/3", 10 MP FA Series MV Lenses

- 12 mm, 16 mm, 25 mm, 35 mm, 50 mm, and 85 mm Fixed Focal Length Options
- *f*/2.0 Maximum Aperture
- C-Mount
- Fits Hikvision Machine Vision Cameras

The MV Series of lenses are made for Hikvision's line of Machine Vision cameras. C-mounts allow the lenses to be quickly interchanged. There is a wide range of focal lengths to satisfy any requirements.

#### Available Models

SA1220M-10MP: 12 mm lens  
SA1620M-10MP: 16 mm lens  
SA2520M-10MP: 25 mm lens  
SA3520M-10MP: 35 mm lens  
SA5020M-10MP: 50 mm lens  
SA8520M-10MP: 85 mm lens

SA1220M-10MP



SA1620M-10MP



SA2520M-10MP



SA3520M-10MP



SA5020M-10MP



SA8520M-10MP



## INTEGRYS

Connecting Technology & Innovation

Toll Free: 888-509-8455, Email: [clientservice@integrsys.com](mailto:clientservice@integrsys.com)  
[www.integrsys.com](http://www.integrsys.com)



# Specifications

	SA1220M-10MP	SA1620M-10MP	SA2520M-10MP	SA3520M-10MP	SA5020M-10MP	SA8520M-10MP		
Specification	Fix focal manual iris 10 MP							
Focal Length	12 mm	16 mm	25 mm	35 mm	50 mm	85 mm		
Mount	C-mount							
f/ No.	f/2.0							
Filter Thread	M77*0.75	M58*0.75	M46*0.75	M40.5*0.5		M77*0.75		
Max Image Format	Φ23 mm (4/3")							
Flange back Length	17.5 mm					17.526 mm		
TV-Distortion	-2.40%	-2.81%	-0.66%	-0.56%	-0.14%	0.04%		
M.O.D	0.15 m	0.1 m	0.15 m	0.2 m	0.3 m	1.2 m		
Control	Manual							
Dimensions	Φ80 mm x 84.4 mm	Φ60 mm x 85.9 mm	Φ47.5 mm x 82.7 mm	Φ44.6 mm x 54.9 mm	Φ44.6 mm x 53.7 mm	Φ80 mm x 111.7 mm		
Operating Temperature	-10° to 50° C							
Field of View	D	89.0°	72.9°	49.7°	36.6°	25.9°	10.75°	15.41°
	H	75.5°	60.9°	40.6°	29.6°	20.9°	8.61°	12.09°
	V	61.1°	47.3°	31°	22.4°	15.7°	6.46°	9.28°

# Dimensions

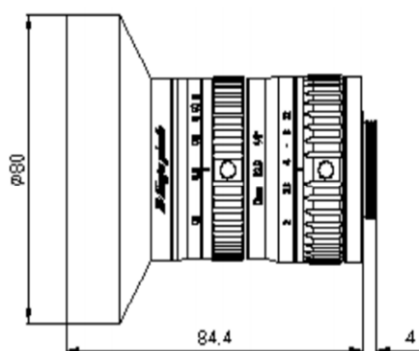

SA1220M-10MP

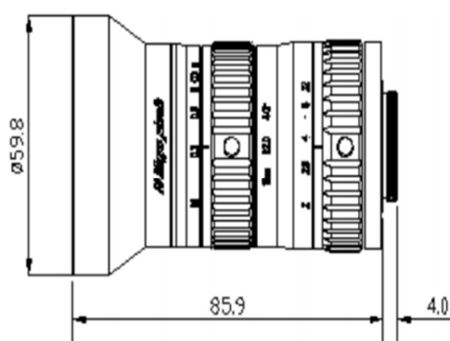

SA1620M-10MP

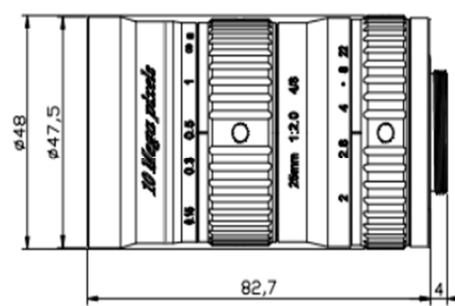

SA2520M-10MP

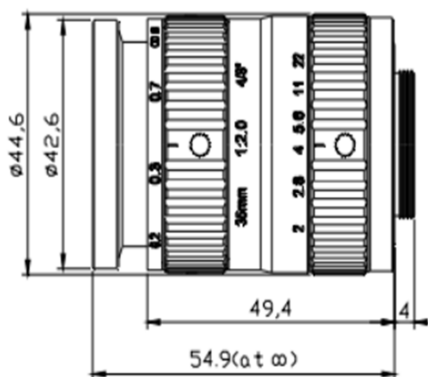

SA3520M-10MP

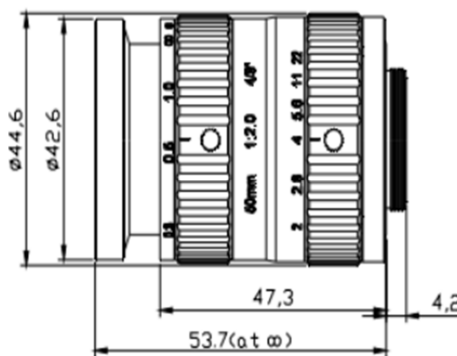

SA5020M-10MP

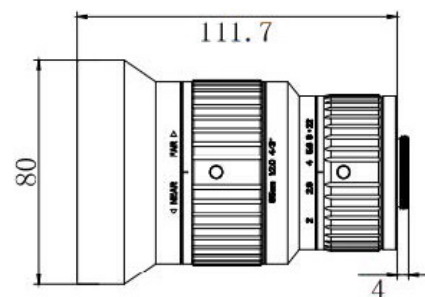

SA8520M-10MP

Units: mm