



MILTECH™ 907

Compact, Portable Military Managed Gigabit Ethernet Switch

FEATURES

The MILTECH 907 is a MIL-STD, fully managed military grade network switch offering 5 triple-speed (10/100/1000Mbps) ports. It can be remotely managed to optimize communications and prioritize critical information traffic. Advanced network features, never before found in a package of this size, include switching protocols, virtual LANS (VLANs), traffic prioritization (QoS), and bandwidth aggregation are standard. The MILTECH 907's gigabit speeds and 24VDC power make it instantly compatible with network device and power systems.

The MILTECH 907 is widely used in battlefield communications C4ISR, video, and sensor data acquisition, and transmission. Its mechanical packaging enhancements, including High Density D-Type 44 pin connector, is designed for MIL-STD-810F airborne and ground environmental compliance and high reliability. Leveraging best-in-class switching technology from Techaya, the MILTECH 907

serves as a robust commercial off-the-shelf (COTS) solution for rugged LAN connectivity, which can be used in a wide range of military and commercial applications, including:

- UAVs
- Land autonomous vehicles (UGVs)
- Robots
- Mobile equipment fielded in harsh environments

Modern platforms contain dozens of network devices that must be interconnected. The MILTECH 907 is an ideal solution for mobile Ethernet-equipped platforms. With the best combination of size, weight, power and cost (SWaP-C) in the industry, it saves valuable real estate for computers, sensors, targeting systems, and other devices that make mobile platforms highly effective.

SPECIFICATIONS

ETHERNET PORTS	<ul style="list-style-type: none"> • 5 x switched 10/100 /1000 ports
NETWORKING	<ul style="list-style-type: none"> • Spanning Tree (802.1d), RSTP (802.1w) and multiple Spanning Tree (802.1S) for fast recovery rings • Security via Radius Authentication 802.1x, Port Security, Port Mirroring • Multicasting (IGMP Snooping), GARP, GMRP, and GVRP Broadcasting and flooding Control up to 8K Groups. • 802.1q Tagged based VLAN up to 4K VLAN groups. • QoS Multi-Layer Classifier, 802.1p, ToS/DSCP traffic classification. WFQ, Strict Queuing. • Bridge support for Q-in-Q. • Link Aggregation 802.3AD. • WEB, CLI, Telnet Management.
CONNECTORS	<ul style="list-style-type: none"> • Single Connector for Power and LAN • 3 Separate pins for RS232 management • LED Indication Per Port (Link/Activity)
CHASSIS	<ul style="list-style-type: none"> • Machined rugged aluminum • Conductively cooled w/custom internal heat-sinks • Ingress protection against sand, dust and moisture • Anodize Coating, MIL-A-8625, Type II, Class 2
STANDARDS	<ul style="list-style-type: none"> • Design to meet: MIL-STD-461E, MIL-STD-810F GM
PERFORMANCE	<ul style="list-style-type: none"> • 26.8 Mpps wire speed forwarding rate • 20 Gbps maximum forwarding bandwidth • 8K MAC Address





MILTECH™ 907

Compact, Portable Military Managed Gigabit Ethernet Switch

SPECIFICATIONS

STANDARDS COMPLIANCE	<ul style="list-style-type: none"> IEEE 802.1x MAC based Authentication IEEE 802.1Q Vlan Tagging IEEE 802.1P QoS IEEE 802.1S Multiple STP IEEE 802.1W Rapid STP IEEE 802.1AD Link Aggregation IEEE 802.1X
POWER	<ul style="list-style-type: none"> MILSTD-1275, MILSTD-704 Voltage Input: 24Vdc Nominal (16-36V) Power Consumption: 5W Max Chassis grounding
ELECTROMAGNETIC	<ul style="list-style-type: none"> Design to meet: MIL-STD-461E Electromagnetic compatibility CE-102, CS-114, CS-115, CS-116, RE-102, RS-103
ENVIRONMENTAL	<ul style="list-style-type: none"> Design to meet: MILSTD-810F/G/GM Random vibration (514.5I), Bench Handling (516.6VI), High Temp.(501.5I,II), Low Temp.(502.5I), Humidity (507.5II), Air Pressure (500.5I,II), Blowing Rain (506.5I), Immersion (512.5I), Salt Atmosphere (509.5I), Blowing Dust (510.5I), Loose Cargo Vibration (514.6II), Wind Analysis.
PHYSICAL	<ul style="list-style-type: none"> Dimensions: 113mm (L) x 54(W) x 40(H), not including connector Dimensions: 4.45"(L) x 2.13"(W) x 1.57"(H), not including connector Weight: 250g
INSTALLATION	<ul style="list-style-type: none"> 4 x 3.2mm mounting holes
COOLING	<ul style="list-style-type: none"> No Moving Parts. Passive Cooling.
OPERATING TEMP	<ul style="list-style-type: none"> -45°C to +85°C (-49°F to +185°F)
STORAGE TEMP	<ul style="list-style-type: none"> -45°C to +85°C (-49°F to +185°F)

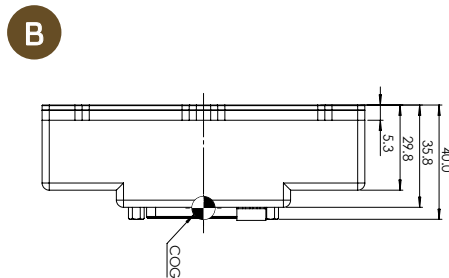
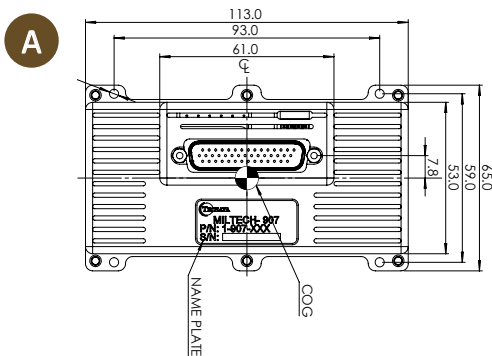

ORDERING INFORMATION

PART NUMBER	DESCRIPTION
1-907-000	Managed Military Grade Gigabit Ethernet Switch, 5 x 10/100/1000TX