

Colibri IP66 (Nema 4 + 6) Industrial Camera Enclosure



IP66 Protection for compact cameras with 29 x 29mm or 30 x 30mm cross section

Technical Highlights:

- **Robust built:** aluminium extrusion profile.
- **Small form factor:** cross section only 50 x 50mm – adding only 10mm around a 30 x 30mm camera!
- **Weight of the enclosure just over 400g:** ideal for light weight applications.
- **Flexible camera positioning:** camera lens mounts directly behind the front window.
- **Robust enclosure mounting:** fixation on all four sides along the entire profile possible. Simple adjustment of working distance.
- **Compatible with dovetail accessories:** with help of an adapter bracket.
- **High chemical resistance:** NBR and TPE sealing materials. Contact us for any special requirements!
- **Vibration proof mounting and passive camera cooling:** thanks to autoVimation's patented Quick-Lock and Heat-Guide camera mounting system (part of delivery).



The Colibri enclosure – only little larger than a compact camera!

- **Camera can be mounted either just from the front or just from the rear side.**
- **Passive camera cooling:** assembled inside the enclosure the camera is at least 10°C cooler than without enclosure.
- **Also available with tamper-proof pin-torx screws.**

Degree of protection	Dimensions	Material details
<ul style="list-style-type: none"> ■ IP66 - Protection from high pressure water jets (Nema 4) 	<ul style="list-style-type: none"> ■ Exclusively for cameras with 29 x 29mm or 30 x 30mm cross section. ■ Cable gland allows for assembly of several cables with connectors up to 20.5mm diameter. ■ Clear aperture 28mm diameter: lenses up to 39mm diameter. 	<ul style="list-style-type: none"> ■ Enclosure: anodised aluminium ■ Window: BK7, double-sided broadband anti-reflective coating. ■ Window seal: Teflon ■ Enclosure seal: NBR (Viton at request) ■ Cable gland seal: TPE (TPEV at request)

Colibri IP66 (Nema 4 + 6) Industrial Camera Enclosure

Dimensions:

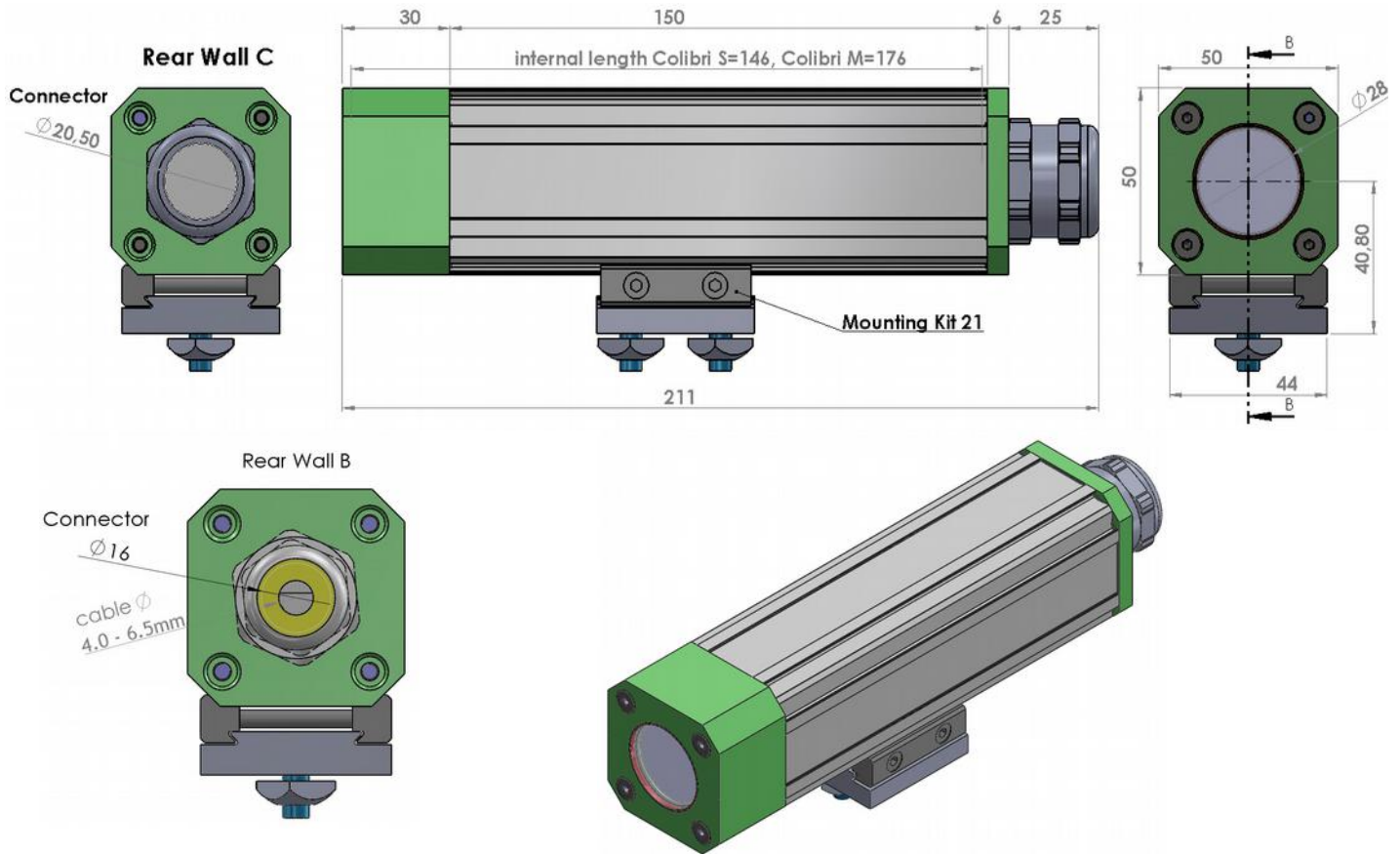

Combinable options:

- Rear wall B: for one cable – cable diameter 4.0-6.0mm and connectors up to 16.0mm (for instance PoE – one LAN cable with standard RJ45)
- Rear wall C for several cables and connectors up to 20.5mm (self drilling of cable gland inserts).

Order number key:

Colibri S, 181 x 50 x 50mm			Colibri M, 211 x 50 x 50mm		
Camera Height	Rear Wall	Order Number	Camera Height	Rear Wall	Order Number
29mm	B	22.901.120	29mm	B	22.901.150
	C	22.902.120		C	22.902.150
30mm	B	23.001.120	30mm	B	23.001.150
	C	23.002.120		C	23.002.150

Accessories:

Product		Order Number	Product		Order Number	Product		Order Number
Air Nozzle + Adapter Clamp		50.100.025 + 10.062.979	Mounting Kit 21		5.210.000	Mounting Kit 26		5.260.000
90° Deflection Mirror + Adapter Clamp		20.020.004 +10.062.979	Mounting Kit 24		5.240.000	Adapter Clamp 30 to 40mm Profile		10.062.979

© autoVimation 2015 subject to change without notice. No liability is accepted for possible errors.