

TOKIN-6083

Fanless 8" Industrial Panel PC with Intel® Celeron® Processor 827E/
Intel® Atom™ Processor D2550



Features

- Less Cable , Fanless Design
- Flexible Modular Design
- 8" 1024 x 768 XGA LCD Display w/ LED Backlight
- Front Bezel with Completely Covered Membrane
- Flush Front Panel, IP65-Compliant
- Brightness Control Button
- Anti-spark Power Circuit
- Outside-accessible Push-pull CFast Sockets
- Isolated Serial Ports (RS-232/485), w/ Auto-flow Control
- 2 x Mini-card sockets, 1 x PCI or 1 x PCIe x1
- Semi-Pierced DB9 Hole Reserved for Field-bus Card
- SMA Antenna Holes for optional WiFi Function
- 9~36V Wide-Range DC Input

System

CPU	Intel® Celeron® Processor 827E 1.4GHz or Intel® Atom™ Processor D2550 1.86GHz
Memory	2 x DDR3 SO-DIMM Sockets, supporting 1333/1066 MHz SDRAM up to 8GB (827E) 1 x DDR3 SO-DIMM Socket, supporting 1066/800 MHz SDRAM up to 4GB (D2550) 1 x 2GB DDR3 SO-DIMM memory module (installed)
Chipset	Intel® HM65 for 827E Intel® NM10 for D2550
LAN	1 x Intel® 82583V GbE controller 1 x Intel® 82579LM GbE PHY
Watchdog Timer	1~255 levels reset
Storage	
1st Device	1 x outside-accessible CFast slot
2nd Device	1 x outside-accessible CFast slot (default), or 2.5" drive bay (included in Standard Accessories)
LCD Display	
Size/Type	8" TFT LCD Panel
Max. Resolution	1024 x 768 (XGA)
Max. Colors	16.2M
Luminance	300 cd/m ²
Touch Screen	5-wire Analog Resistive
View Angle (U/D/R/L)	75°/75°/70°/70°
Button & Indicator	
Function Key	Brightness up/down, Screen on/off
LED Indicator	Power on LED
Power System	
Power Input	DC 9~36V
Certification	
EMC / EMI	CE, FCC Class A
Expansion	
Expansion Bus	2 x Mini-card sockets 1 x PCI 32-bit slot (default, for limited-length expansion card only, 150 mm maximum) or 1 x PCIe x1 slot (included in Standard Accessories)
Optional	1 x Internal USB dongle space

External I/O

Serial Ports	2 x RS-232 and 2 x isolated RS-232/485 ports, all are DB9 connectors
USB Ports	4 x Type-A USB 2.0 ports
LAN	2 x RJ-45 GbE ports
DVI	1 x DVI-I connector
Optional Port	1 x semi-pierced DB9 hole reserved for internal wiring by user
WiFi	2 x SMA antenna holes for optional WiFi function

Mechanical

Mounting Type	Panel Mounting and VESA-75/100 Mounting
Chassis	Panel-mounting chassis, aluminum front bezel and SECC steel chassis
Dimension (W x H x D)	274.96 x 207.96 x 77.0 mm (10.82" x 8.18" x 3.03")
Weight (Net)	4.5 kg (9.92 lb)

Environmental

Operating Temp.	-20 ~ 60°C (-4 ~ 140°F)
Storage Temp.	-20 ~ 70°C (-4 ~ 158°F)
Operating Humidity	10 ~ 95% RH @ 60°C (non-condensing)
Vibration	5 ~ 500Hz, 2Grms Random (with CF/SSD)
Shock	Operating 15G, 11ms Non-operating 40G, 11ms (with CF/SSD)

OS Support

Windows XP Embedded / Windows Embedded 7 /
Windows Embedded Compact 7 (D2550 only)

Ordering Information

TOKIN-6083-827E	Intel® Celeron® 827E industrial panel PC w/ 2GB memory
TOKIN-6083-D2550	Intel® Atom™ Processor D2550 industrial panel PC w/ 2GB memory

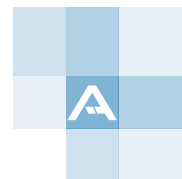

Dimensions

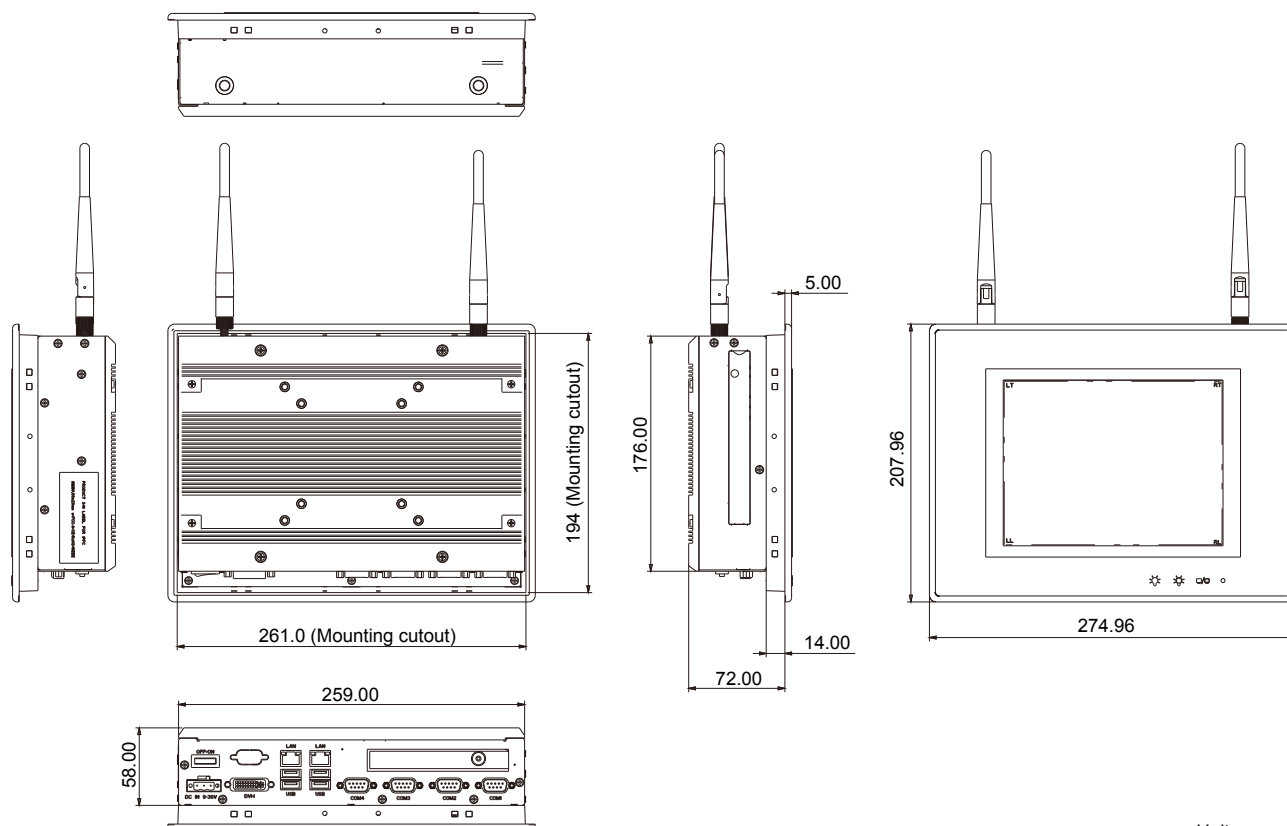

Unit: mm

Standard Accessories

EPC-6300 HDD Bracket 2.5" HDD/SSD Bracket



SCDB-1395 PCIe x1 Riser Card



Optional Accessories

PAC-P065W 19V/3.4A 65W AC/DC power adapter kit



PAC-P120W-FSP 19V/5.96A 120W AC/DC power adapter kit



Optional Accessories (CTOS* Kit)

80GB SSD Intel® 2.5" 80GB SATAIII SSD kit



MM-3C-2G 2GB DDR3-1333 SDRAM



MM-3C-4G 4GB DDR3-1333 SDRAM



WiFi-AT2350 Atheros AR9462 WiFi Module w/ 20cm & 30cm internal wiring



ANT-D11 2.4G/5G Dual-band WiFi Antenna



*CTOS means Configure-to-Order Service.