

**Digital Color  
Progressive Scan Camera**

 System: **Gigabit Ethernet**
**Baumer TXG20c**

 Art. No: **OD108069**

- Gigabit Ethernet progressive scan CCD camera
- 1616 x 1228 pixel
- Up to 16 full frames per second
- GigE Vision™ standard compliant
- On board integrated color processor for high quality color calculation
- Outstanding image quality
- High sensitivity and dynamic range
- High quality slow scan mode for lowest readout noise
- True partial scan function (ROI) for increased frame rates
- External synchronization via industrial compliant process interface (trigger / flash)
- Supported jumbo frames
- Integrated 32 MByte RAM for temporarily image data buffering
- Camera parameter programmable in real-time
- Ultra compact and lightweight aluminum housing
- Standard RJ45 connector
- Screw-lock type industrial connector
- Baumer-GAPI: Flexible, generic software interface for Windows / Linux



shown lens needs to be ordered separately

**1. Overview**

<b>Sensor</b>	1/1.8" interline progressive scan CCD
Shutter / readout mode	global shutter / progressive scan readout
Number of pixel	1624 x 1236
Scan area	7.15 mm x 5.44 mm
Pixel size	4.4 µm x 4.4 µm
Color filter	RGB Bayer mosaic
<b>Operation modes</b>	
Trigger mode	yes, overlapped operation
Free running mode	yes, overlapped operation
<b>Signal processing</b>	real-time software programmable
Pixel clock	40 MHz fast scan / 20 MHz high quality (HQ) scan
A/D converter	12 bit
Exposure control (t <sub>exp</sub> )	total: 4 µsec .. 60 sec step 1 µsec
Gain control	0 .. 20 dB
Offset (black level)	0 .. 255 LSB (12 bit)
Image data buffer	32 MByte

Technical specifications subject to change

Image acquisition								
Data format	YUV , RGB , BGR , Mono8 or Raw image data from camera							
Camera image format modes	Format (pixel)	Gen-Cam standard	Format ID	Pixel format	Pixel clock MHz	Frames per sec. *)	t <sub>readout</sub>	
Full frame HQ Raw	slow	1624 x 1236	Vendor specific	00	BayerRG8 **)	20	8	125 msec
					BayerRG12			
Full frame Raw	fast	1624 x 1236	yes	01	BayerRG8 **)	40	16	63 msec
					BayerRG12			
Full frame HQ	slow	1616 x 1228	Vendor specific	02	Mono8	20	8	125 msec
					YUV411 Packed			
					YUV422 Packed **)			
					YUV444 Packed			
					RGB8 Packed			
					BGR8 Packed			
Full frame	fast	1616 x 1228	yes	03	Mono8	40	16	62.5 msec
					YUV411 Packed			
					YUV422 Packed **)			
Stream channel packet size	576 Byte .. 16 kByte jumbo frames supported							
Partial scan function	yes, format freely programmable in all modes							
Look up table function	on request: user programmable (input 12 bit, output 12 bit / 8 bit) or Gamma							
Test pattern function	yes, in all modes							
<b>Advanced features</b>								
Time stamp function	yes							
Resend function	yes							
Asynchronous message channel	on request							
Data quality	at 20 °C, gain = 1, exposure time = 32 msec, full frame mode, slow scan							
Readout noise	$\sigma < 0.5$ LSB (8 bit) typical							
Dynamic range	typical > 54 dB							
Optical interface	C-Mount on request: CS-Mount							
Optical filter	Hoya E-CM500S on request: super polished, dust protection, daylight filter or no filter							
<b>Process interface functions</b>								
Ethernet IP configuration	static IP / DHCP / LLA							
Async. Trigger	yes, trigger mode operation, software trigger and external trigger separately selectable external trigger in trigger mode 0 (overtriggered signals and trigger signals during the readout time will be notified in the received image header)							
External flash sync	yes, delay_value $\leq 4$ $\mu$ sec, duration_value (t <sub>duration</sub> ) : slow mode = t <sub>exp</sub> + 99 $\mu$ sec fast mode = t <sub>exp</sub> + 50 $\mu$ sec							
Software reset	yes, delay up to 125 msec							
Asynchronous reset	Full frame	slow	delay up to 17.7 msec					
		fast	9.5 msec					
Image info header	yes							
User defined identifier	on request : user programmable permanent identifier							
<b>Electrical interface</b>								
Data / control	standard single cable 1000 Base-T, Cat6 option: screw lock type connector							
Power	VCC: 8 VDC .. 30 VDC I: 563 mA .. 135 mA							
Power consumption	approx. 4.5 Watt							



### 3. Timing Operation Modes

Trigger Mode: start up time

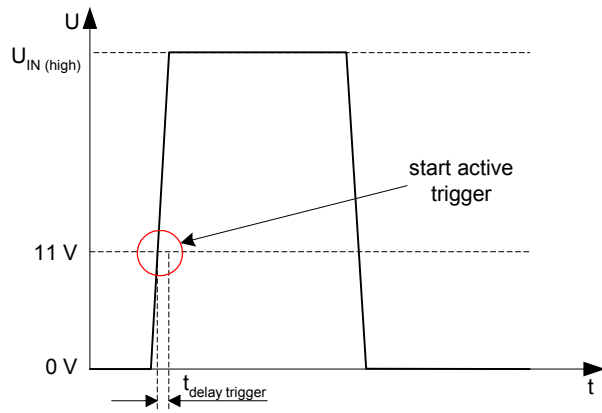

Trigger Mode: trigger mode 0, overlapped trigger

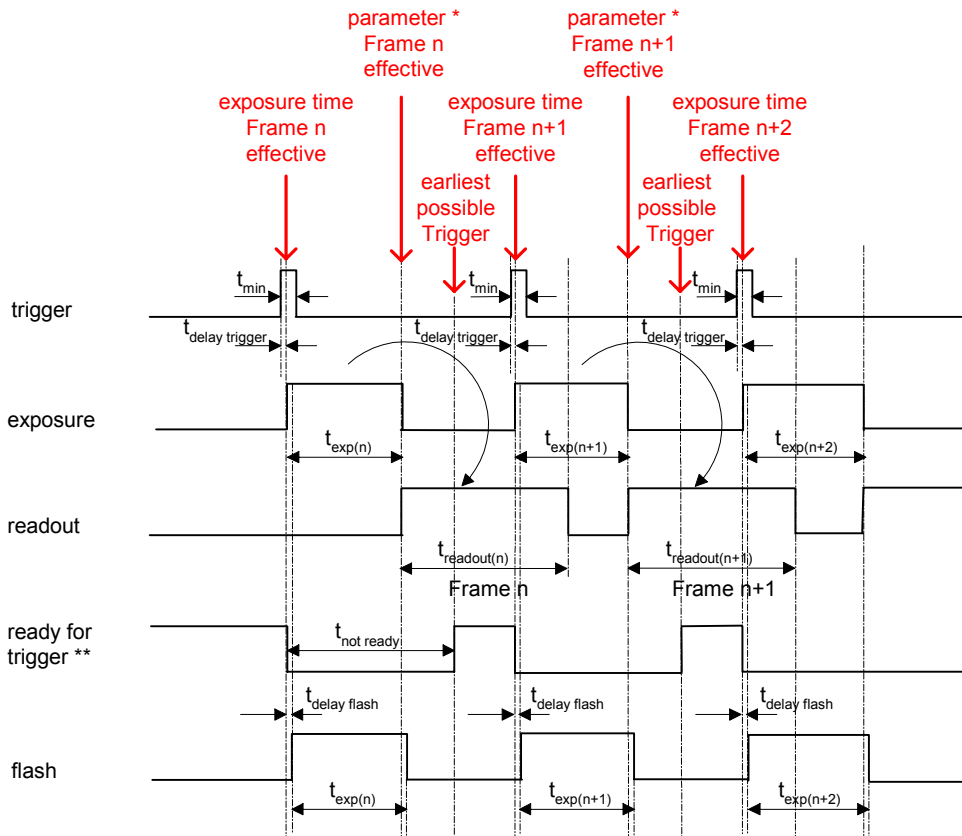

$$t_{exp} < t_{readout}: t_{earliest\ possible\ trigger\ (n+1)} = t_{readout(n)} - t_{exp(n+1)}$$

$$t_{exp} > t_{readout}: t_{earliest\ possible\ trigger\ (n+1)} = t_{exp(n)}$$

$$t_{exp} < t_{readout}: t_{not\ ready\ (n+1)} = t_{exp(n)} + t_{readout(n)} - t_{exp(n+1)}$$

$$t_{exp} > t_{readout}: t_{not\ ready\ (n+1)} = t_{exp(n)}$$

\* image parameter:    offset  
                               global gain  
                               mode  
                               partial scan

\*\* signal is not available as digital output

Trigger Mode: trigger mode 0, overlapped trigger , when  $t_{exp(n+2)} > t_{exp(n+1)}$

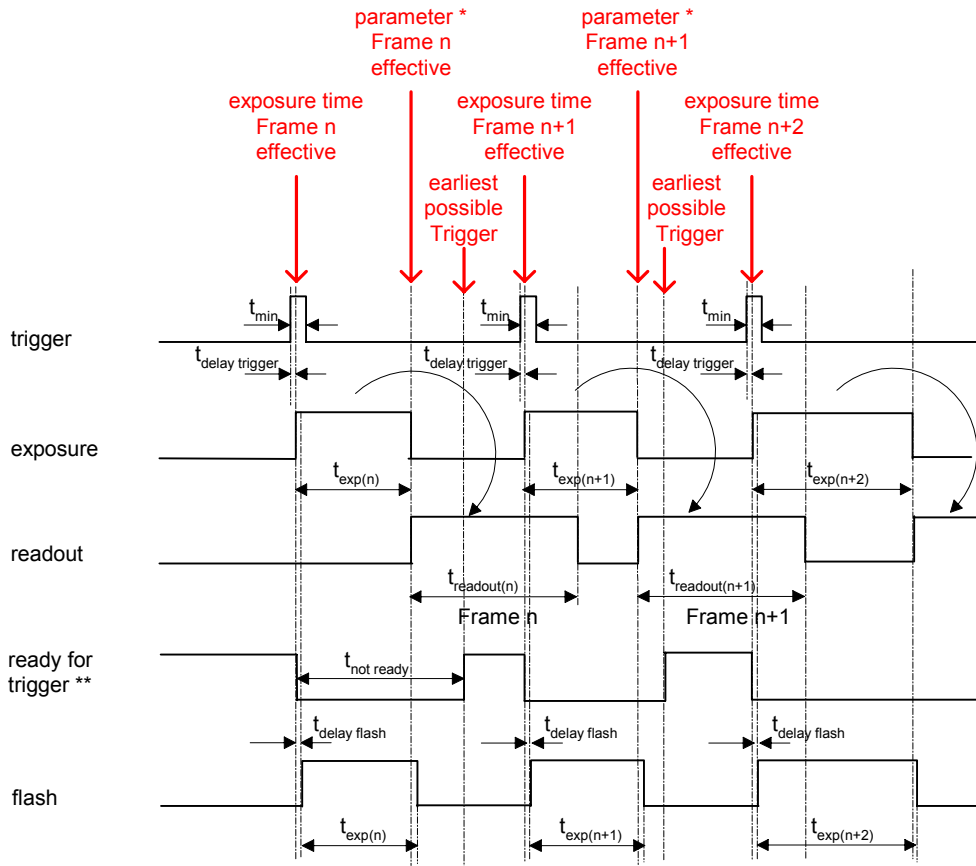

$$t_{exp} < t_{readout}: t_{earliest\ possible\ trigger\ (n+1)} = t_{readout(n)} - t_{exp(n+1)}$$

$$t_{exp} > t_{readout}: t_{earliest\ possible\ trigger\ (n+1)} = t_{exp(n)}$$

$$t_{exp} < t_{readout}: t_{not\ ready\ (n+1)} = t_{exp(n)} + t_{readout(n)} - t_{exp(n+1)}$$

$$t_{exp} > t_{readout}: t_{not\ ready\ (n+1)} = t_{exp(n)}$$

\* image parameter:    offset  
                               global gain  
                               mode  
                               partial scan

\*\* signal is not available as digital output

Trigger Mode: trigger mode 0, overlapped trigger , when  $t_{exp(n+2)} < t_{exp(n+1)}$

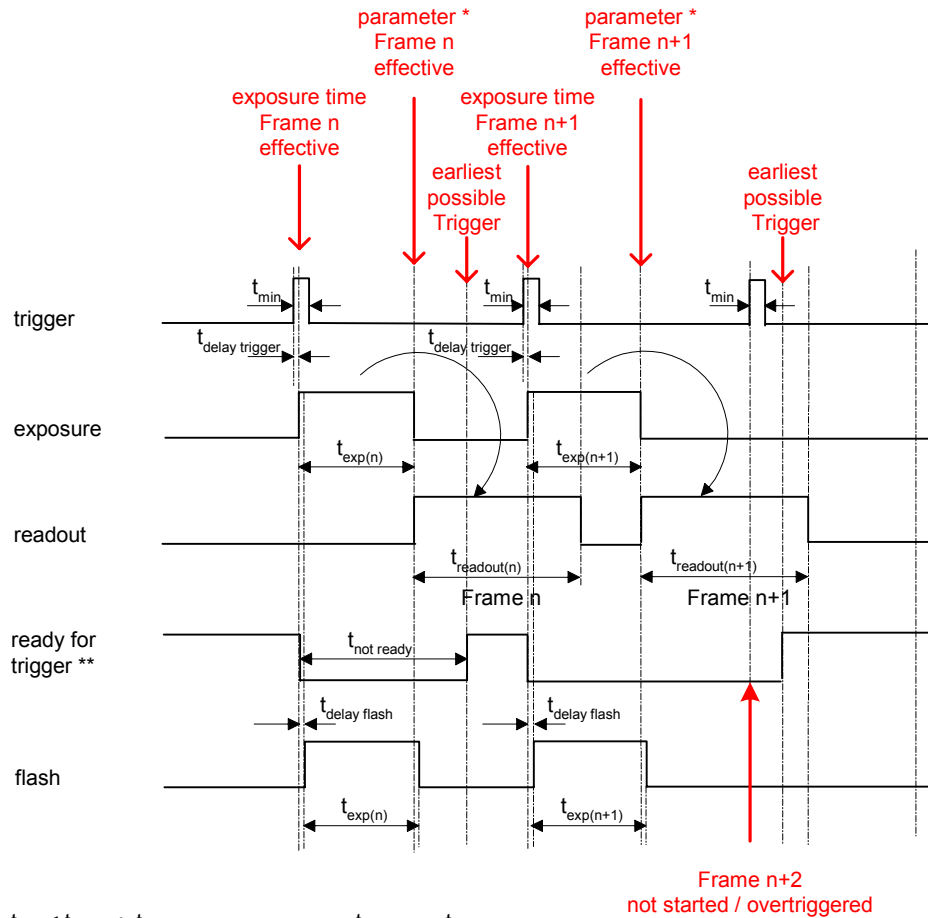

$$t_{exp} < t_{readout}: t_{earliest\ possible\ trigger\ (n+1)} = t_{readout(n)} - t_{exp(n+1)}$$

$$t_{exp} > t_{readout}: t_{earliest\ possible\ trigger\ (n+1)} = t_{exp(n)}$$

$$t_{exp} < t_{readout}: t_{not\ ready\ (n+1)} = t_{exp(n)} + t_{readout(n)} - t_{exp(n+1)}$$

$$t_{exp} > t_{readout}: t_{not\ ready\ (n+1)} = t_{exp(n)}$$

\* image parameter: offset  
global gain  
mode  
partial scan

\*\* signal is not available as digital output

Free Running Mode: overlapped operation

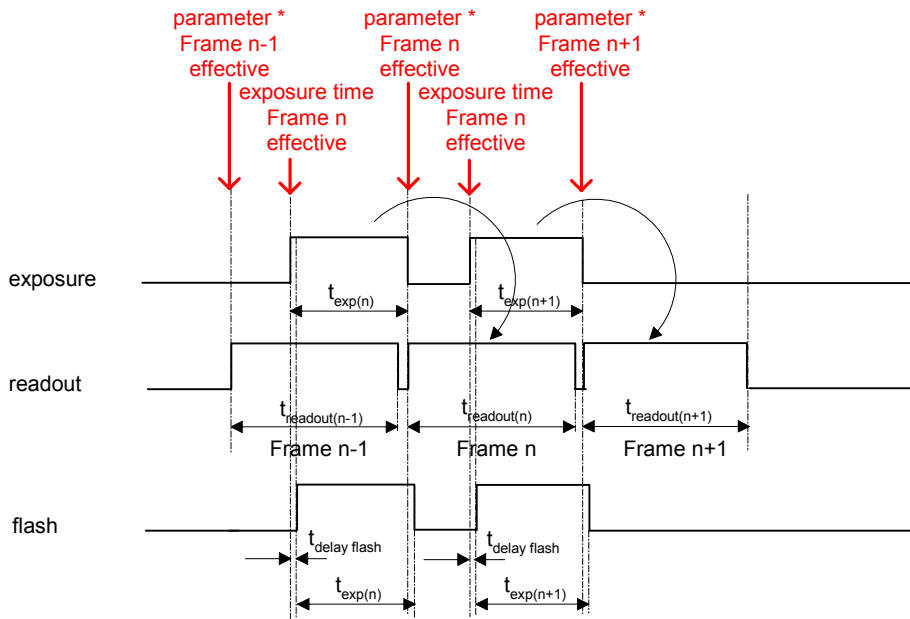

\* image parameter: offset  
global gain  
mode  
partial scan



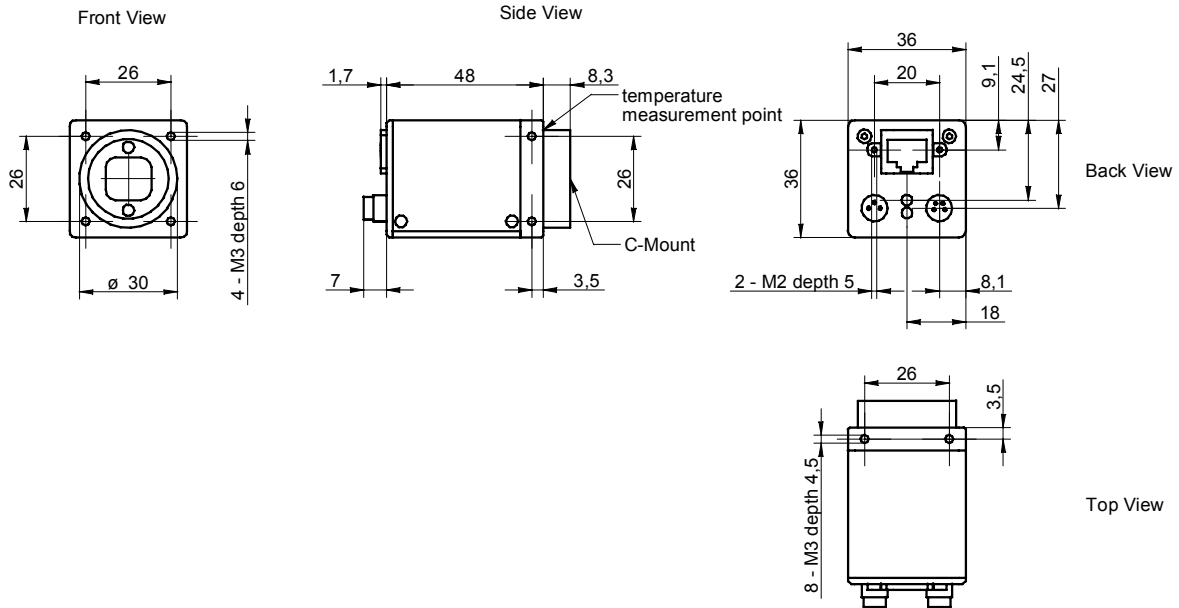

### 4. Housing

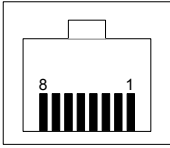

### 5. Connectors / Electrical Interfaces

#### 5.1 Pin assignment:

<b>Data / Control</b> <b>1000 Base-T</b>	Type: RJ45 8P8S mod jack
	<ul style="list-style-type: none"> <li>1: MX1+</li> <li>2: MX1-</li> <li>3: MX2+</li> <li>4: MX3+</li> <li>5: MX3-</li> <li>6: MX2-</li> <li>7: MX4+</li> <li>8: MX4-</li> </ul>

<b>Power</b>	Type: Lumberg RSME5D / 3 pin
	<ul style="list-style-type: none"> <li>1: Power VCC+</li> <li>3: GND</li> <li>4: not used</li> </ul>
	Power cable wires color: 1 = brown 3 = blue 4 = black

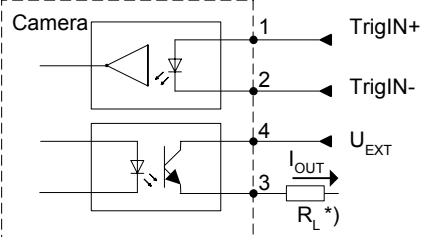
<b>Trigger / Flash</b>	Type: Lumberg RSME5D 4pin.
	
	*) resistor must be used, $I_{OUT} = 16 \text{ mA}$ by $U_{EXT} = 24 \text{ VDC}$ recommended, drawing shown above example for using high active signal
	Trigger / Flash cable wires color *): 1 = brown 2 = white 3 = blue 4 = black

\*) shielded trigger / flash cable should be used and ordered separately

5.2 Flash sync sample  $U_{EXT} = 24\text{ VDC}$  high active:

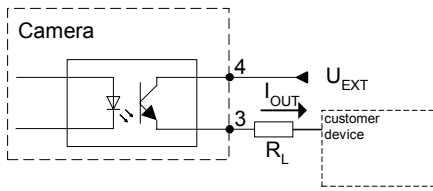

Timing example:  
measurement condition  $U_{EXT} = 24\text{ VDC} / I_{OUT} = 16\text{ mA}$

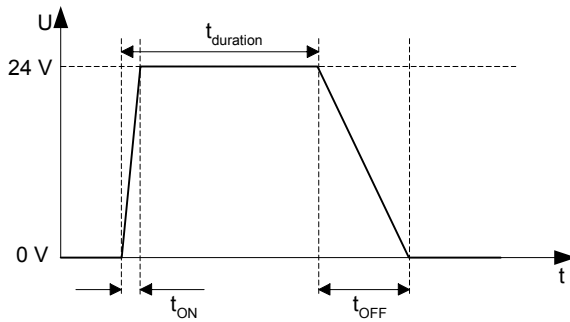

$t_{ON}$  time = typ. 2  $\mu\text{sec}$   
 $t_{OFF}$  time = typ. 40  $\mu\text{sec}$

5.3 Flash sync sample  $U_{EXT} = 24\text{ VDC}$  low active:

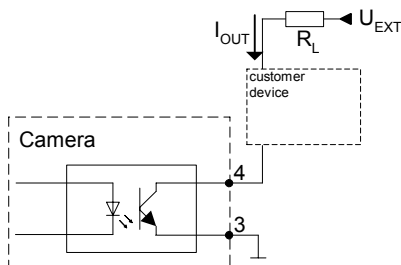

Timing example:  
measurement condition  $U_{EXT} = 24\text{ VDC} / I_{OUT} = 16\text{ mA}$

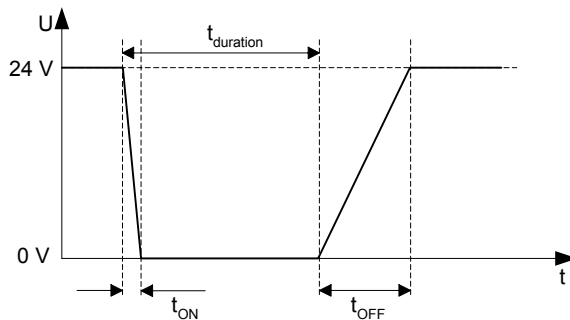

$t_{ON}$  time = typ. 2  $\mu\text{sec}$   
 $t_{OFF}$  time = typ. 40  $\mu\text{sec}$

End of Document