

RL36120

Bright Field Ring Light



- 4i** Intense illumination for large areas, where specular reflection is not a problem
- 4i** Available in the RGB "All Color" version

Ordering Information

Standard Product:
Shipped Next Day

RL36120-660200XL

Configured for use with Ai Power Supply

Standard Product Variation:
Shipped Within Two Weeks

Mounting option	Spectral wavelength	Stand off	Field of view	Optional power Compatibility	Optional Light Conditioning	Alternative Connector
RL36120 X	XXX	XXX	XXX	XX	X	XXX
B	(UV) 395 [◇] (blue) 470 [†] (green) 520 [†] (yellow) 590 (orange) 625 (red) 660 [⊙] (infra-red) 880 [⊙] (white) WHI [†] (all color) RGB ^{†!}	See chart to compute standoff.	XXL XL L M S XS	IC IS C2 C3 C5 12 24	D (Diffuser) P (Polarizer)	M12* (male)

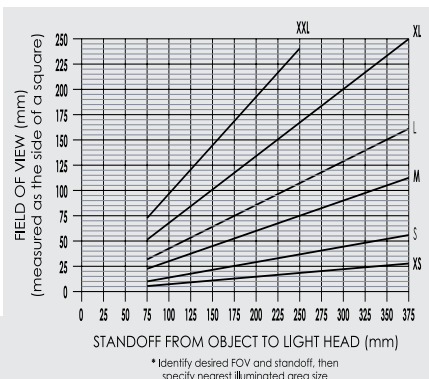
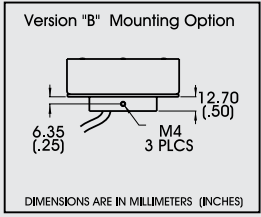

Dimensional Information

Includes Mounting Bracket
(Part # CB092)

[Click for Installation Models & Drawings](#)

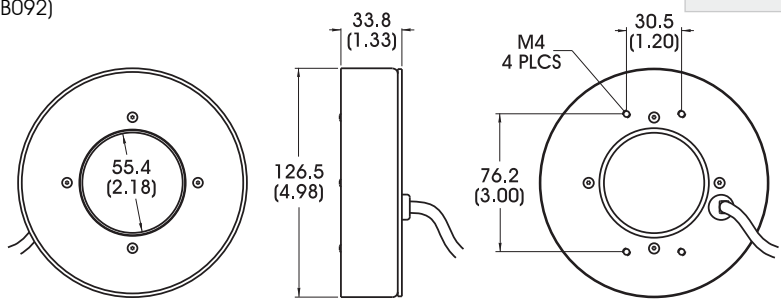

◇ UV LEDs have a considerably shorter half-life than other LEDs (< 1000hrs). For this reason Ai recommends these LEDs be used in strobe mode only. applications requiring continuous 24v power, contact Ai for assistance.

- IC = ICS (requires 24v power supply)
- IS = ISU (requires 24v power supply)
- ⊙ IS option not available
- C2 = Ai Connector
- C3 = Pulsar 710 Connector
- C5 = Pulsar 320 Connector
- * Available with IC, IS, and 24v options only
- † Not available in 12v
- ! - Not available in IC, IS or C5

Cable length: 1.5 Meters (59")

DIMENSIONS ARE IN MILLIMETERS (INCHES)

	blue	green	yellow	orange	red	infra-red	white	RGB	
@12	N/A	N/A	400	400	600	640	N/A	N/A	mA
@24	480	480	240	240	360	280	480	440	mA

Standard Product Information	
Product Lifetime:	50,000 hours
Operating Temperature:	0-60° C