

Condor VC102x

Simultaneous Raw Video Capture and H.264 Compression Rugged XMC Card with HD-SDI/Composite Video Inputs and 1Gb Ethernet outputs

Features

- H.264 Streaming—2 SDI, 4 Composite Video or 1 SDI + 2 Composite Video at the same time
- Raw Video Capture—2 SDI or 2 Composite Video at the same time
- H.264/AVC Baseline, Main or High Profile Video Compression up to L4.1 or MJPEG
- Two 1Gb Ethernet outputs provide H.264 RTP/RTSP/UDP stream
- Raw video captured to host with low latency for immediate display
- Stream to file on host machine
- XMC form factor
- Low Power ($\approx 10W$)
- 2 Stereo audio inputs synced to video
- Convection/Conduction cooled

Markets

- Military/Avionics/Industrial
- ISR (Intelligence, Surveillance, Reconnaissance)
- Embedded Systems
- UAV (Unmanned Aerial Vehicles)

Platforms

- Linux/Windows 7 on x86 based Single Board Computers
- VME, cPCI, VPX
- VxWorks on x86 and PowerPC

The Condor VC102x is a rugged XMC card that supports high definition (HD) or standard definition (SD) raw video capture and H.264/MJPEG video compression. The versatile card serves as a frame grabber as well as a H.264 encoder.

Condor VC102x provides raw video to the host machine over PCIe with extremely low latency to allow for real time viewing, processing, analysis or display from a local graphics card. Either two HD/SD-SDI or two composite video inputs can be captured as raw data at the same time.

The card simultaneously does hardware based H.264 encoding and sends the encoded streams to two 1Gb Ethernet ports on the board for streaming to a local or remote location. The video streams are available as RTP/RTSP/UDP or can be recorded to a file on the host machine. VC102x supports streaming of two HD/SD-SDI or four composite video inputs at the same time. It also supports a combination of one HD/SD-SDI and two composite video inputs. This XMC form factor card is designed for use in various applications such as surveillance, image detection, video recording, unmanned vehicles (UAV) and other camera based video recording and analysis. VC102x also accepts 2 stereo audio inputs that are synced with the video stream.

The board has low power consumption ($\approx 10W$) that makes it ideal for applications such as UAVs and other systems where SWAP (size, weight and power) considerations are critical. The hardware compression minimizes CPU usage.

Various video input formats (NTSC/PAL/RS-170/SD-SDI/HD-SDI) are selectable through an API. A full SDK is provided to manage captured video and audio data. Condor VC102x is available in various levels of ruggedization and has convection or conduction cooled variants.

The product comes with Tech Source's commitment of availability for up to 7 years. This comes with technical support from our team to provide immediate assistance to troubleshoot and resolve any technical challenges. Linux and Windows 7 drivers are available by default. Other real time operating systems (RTOS) such as VxWorks are also supported.

Tech Source has provided video solutions for over 25 years and has always met customer needs with long term commitment and support.

Tech Source
An EIZO Group Company

Condor VC102x Specifications

Interface	XMC form factor, 4 Lane PCI Express Interface
H.264 Encoding Format	H.264/AVC Baseline, Main or High Profile up to L4.1 or MJPEG (configurable)
Video Inputs	Two HD-SDI, SD-SDI, 75 Ω Resolutions up to 1080p30 or 1080i60 Interfaces: SMPTE 292M(HD), SMPTE 259M-C(SD)
	Four Composite Video (TV), 75 Ω (NTSC/PAL/RS-170)
Raw Video Capture	Supports capture of Two HD/SD-SDI or Two Composite Video at a time
H.264 Video Streaming	Supports H.264 encoding of Two HD/SD-SDI, Four Composite Video or One HD/SD-SDI + Two Composite Video at a time.
Audio Inputs	Two SDI audio inputs (SMPTE 272M-C and SMPTE 299M), Two stereo line inputs, 20 kΩ
Outputs	Raw Uncompressed Data over x4 PCIe to host Two 1Gb Ethernet ports - H.264 Compressed Data (RTP/RTSP/UDP) Stream to file on host machine
Power Rating	≈10 Watts
Operating Temperature	0°C to 55°C (Standard)
	-40°C to 70°C (Rugged Convection Cooled)
	-40°C to 85°C (Rugged Conduction Cooled)
Non-operating Temperature	-40°C to 85°C (Standard)
	-55°C to 105°C (Rugged Convection Cooled)
	-55°C to 105°C (Rugged Conduction Cooled)
Vibration	0.04 g ² /Hz, 5-2K Hz (Standard)
	0.1 g ² /Hz, 5-2K Hz (Rugged)
Shock	20g peak (Standard), 40g peak (Rugged)
Conformal Coating	Available (Standard with conduction cooled version)
Humidity	90% without condensation, 95% (For Rugged)
Dimensions and Weight	149mm x 74mm (Convection, Front I/O), 143.75mm x 74mm (Conduction); 4.0 oz
Software/Platform Support	Linux or Windows 7
	RTOS support—VxWorks
	x86 (now), PowerPC (Future)

Condor VC102x Block Diagram

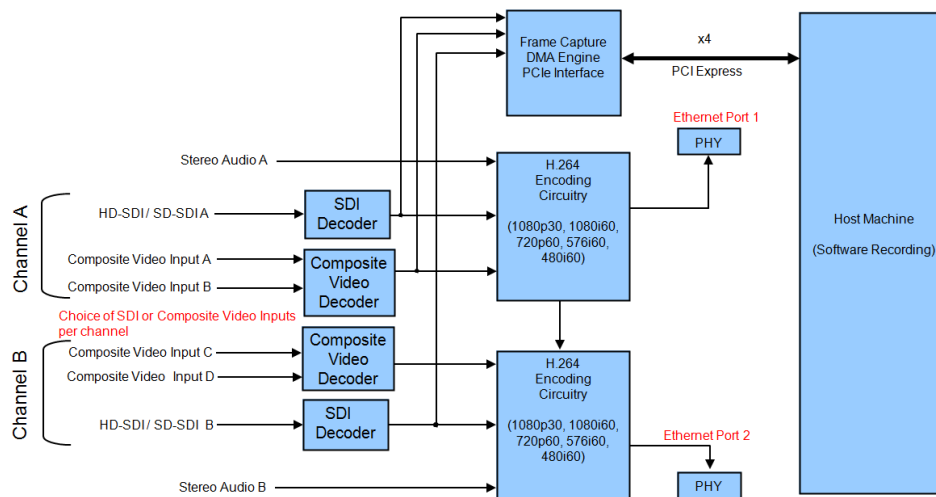

Tech Source
An EIZO Group Company

442 Northlake Blvd,
Altamonte Springs, FL 32701, USA
407.262.7100, embeddedgraphics@techsource.com

www.techsource.com



Tech Source, the Tech Source logo and Condor VC102x are trademarks of Tech Source, Inc. EIZO name and logo are registered trademarks of EIZO Corporation. All other trademarks are the property of their respective owners. ©2014 Tech Source, Inc. All rights reserved. Information in this document is subject to change without notice. Tech Source, Inc. assumes no responsibility for errors or omissions that may appear in this document.