

Basler Time-of-Flight Camera

PICTURES IN NEW DIMENSIONS



GIG
VISION

- Pulsed Time-of-Flight Camera with 2D image capability
- VGA resolution
- Ease of use: GigE interface – GigE Vision and GenICam 3D compliant
- Vision Systems Design Innovators Award Gold winner in 2015

OVERVIEW

Time-of-Flight Cameras for 3D Shape and Volume Measurement

Basler is developing a pulsed Time-of-Flight (ToF) camera with standard machine vision interface and functionality that will make 3D shape and volume measurement applications quick and easy.

Basler's ToF camera is equipped with a pulse-emitting high-power IR light source for range measurement.

The measurement principle is based on the time the light needs to travel from the light source to the object and back to the camera. The further the distance, the longer the time. Both light source and image acquisition are synchronized in such a way that the distances can be extracted and calculated from the image data.

This measurement principle can also be found in the animal world. There, dolphins use sonar to navigate. Our camera works the same way, but it uses light, not sound.

Powered by unique cutting-edge ToF Panasonic CCD sensor technology, this system achieves best-in-class 2D resolution while maintaining a high level of depth accuracy. With the rich lineup of color and mono versions planned, our users can choose from multiple options to find the best option for their needs.

The combination of 2D and depth image in one shot from one camera makes 3D imaging easy without sacrificing the 2D image potential. This also makes the camera setup and integration process elementary for system manufacturers while reducing total system costs.

Over a broad working range of 50 cm - 5 m, Basler's ToF camera can achieve a high depth accuracy of +/-1 cm. Higher levels of depth accuracy should be possible in closed environments.

Simple depth displacement analysis can speed up XY triangulation. Finally, with its integrated NIR light source, our camera is impervious to ambient light and can even see in the dark!

Your benefits include:

- Being independent of ambient light, the Basler ToF camera can even see in the dark
- 2D image with per-pixel depth information (2D + 3D)
- Easy to integrate and use
- Total system cost reduction
- Industry standard interface
- Flexible product for broad variety of applications
- 3D modeling possible
- Automatic exposure control and scene-specific presets
- NIR LED's used
- Optimized for indoor applications

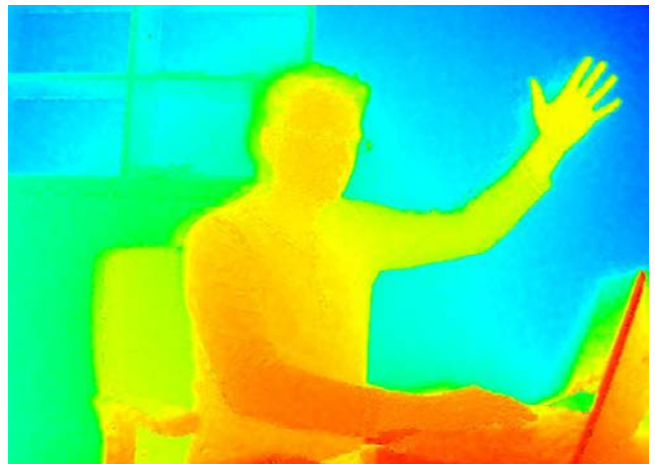

Sample "Gesture Control" Image Taken by ToF Camera

TYPICAL APPLICATIONS

A Basler ToF camera can be used in a wide variety of applications. Examples include:

Logistics Automation

Basler ToF cameras can be used for shipment packaging assistance, e.g. box filling, box or pallet stacking, volume scanning, or labelling / OCR. It can also be used for shelf robot assistance or for luggage and box routing.



Factory Automation and Robotics

Factory Automation and Robotics are other fields that offer a wide range of application possibilities for the Basler ToF camera. In bin picking machines, for instance, the ToF camera can:

- Find objects
- Pick objects
- Mount objects
- Detect damaged objects
- Detect stacking failures



In addition, there are many more applications in the field of parts inspection: Basler ToF cameras play an integral role in monitoring the packaging and size of parts, and control their completeness during the manufacturing process, thus providing valuable support in quality inspection.

Medical

In the Medical field the Basler ToF camera can be used in various applications. Examples are patient monitoring or patient positioning in systems like magnetic resonance tomography. Furthermore, the ToF camera can be deployed in various applications of Biometrics. Particularly in this area the third dimension will open a whole set of new possibilities.



Autonomous Vehicles

For autonomous vehicles, the ToF camera can be a valuable tool for navigation, utilizing the depth information for obstacle avoidance, and the 2D data for standard image processing.



TECHNICAL DETAILS

Specifications

Camera	Basler ToF Camera
Sensor Vendor	Panasonic
Resolution	640 × 480
Type	NIR
Frame Rate	15 fps
Working Range	0.5m to 6.6m
Accuracy	+/- 1cm*
Interface	Gigabit Ethernet, GigE Vision and GenICam compliant
Lens	FOV: 57°× 43°
Software	Windows and Linux
Exposure Control	Programmable or Auto Mode
Synchronization	Free-Run, Programmable
Digital I/O	2 in/4 out
Operating Temperature	0°C - 50°C
Weight	-0.4 kg
Power	24VDC, 15W
Conformity	CE, RoHS, GenICam, GigE Vision, FCC, Eye safety EN 62471:2008

Specifications and housing are subject to change without prior notice.

*Scene dependent: in a range of 0.5m to 5m, based on a flat white target with over 90% reflectivity, in a room with zero ambient light at 22°C, in factory settings mode, looking at the center of the range image.

Dimensions (in mm)

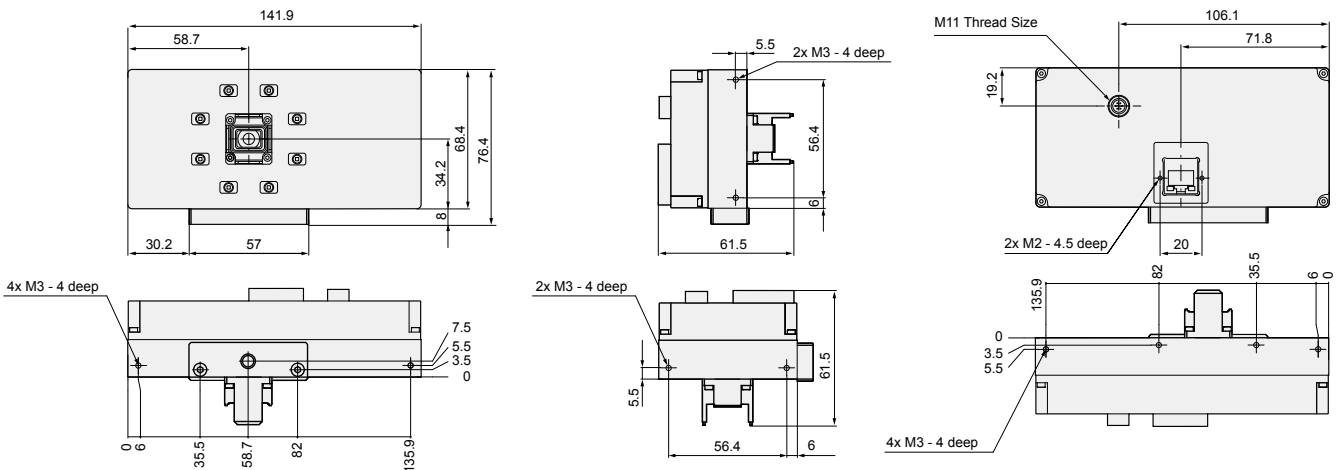

©Basler AG, No. 03, 04/2016
ID 2200000022

Basler AG
Germany, Headquarters
Tel. +49 4102 463 500
sales.europe@baslerweb.com

Basler, Inc.
USA
Tel. +1 610 280 0171
sales.usa@baslerweb.com

Basler Asia Pte Ltd.
Singapore
Tel. +65 6367 1355
sales.asia@baslerweb.com

Please visit our website to find further Basler offices and representatives close to you:
www.baslerweb.com/sales

