

Matrox 4Sight GpM >>>

with Matrox Design Assistant



**New
entry-level
model
available**



Fanless industrial imaging computer with an intuitive, versatile and extendable integrated development environment for machine vision applications



Matrox 4Sight GPM with Matrox Design Assistant

Rugged, capable and configurable vision systems

Matrox 4Sight GPM with Design Assistant is a line of rugged, capable and configurable vision systems for rapid development and deployment onto the factory floor without the need for conventional programming. Equipped with up to four Gigabit Ethernet ports with power and up to four SuperSpeed USB ports, Matrox 4Sight GPM supports the use of multiple GigE Vision® and USB3 Vision™ industrial cameras to keep an eye on one or many production lines. Powered by a range of mobile-class embedded Intel® processors, it has the ability to cost-effectively handle typical multi-camera inspection applications. It can easily directly connect to factory automation equipment and enterprise systems through discrete I/O, Ethernet, RS232/RS485 and USB ports. An industrial-strength design and careful component selection ensure its long term availability.

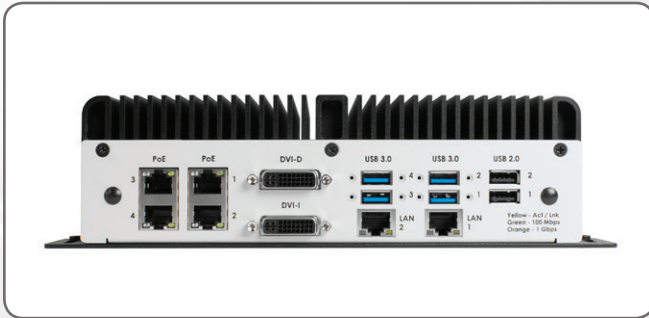

Matrox 4Sight GPM (Ivy Bridge)



Matrox 4Sight GPM (Bay Trail)

Matrox 4Sight GPM Benefits

Tackle typical vision workloads with a mobile-class embedded Intel® processor

Employ the right image sensor format, resolution and frame rate for the job by connecting any GigE Vision® or USB3 Vision™ camera

Inspect multiple sites through the support for up to four GigE Vision® and up to four USB3 Vision™ cameras

Simplify cabling for GigE Vision® installations using Power-over-Ethernet (PoE) enabled ports

Connect separately to the factory floor and enterprise networks via up to two more Gigabit Ethernet ports

Synchronize with other automation equipment using the integrated real-time digital I/Os with rotary encoder support and RS232/RS485 ports

Install in space-limited hostile environments with a small footprint ruggedized casing

Reduce service stoppages with a fanless design

Employ for the long run with assurance as a result of a managed extended lifecycle

Industries served

Matrox Design Assistant is used to put together solutions for the agricultural, aerospace, automotive, beverage, consumer, construction material, cosmetic, electronic, energy, food, flat panel display, freight, machining, medical device, paper, packaging, pharmaceutical, printing, resource, robotics, security, semiconductor, shipping, textile, and transportation industries.

Matrox Design Assistant

Matrox Design Assistant¹

New Matrox Design Assistant flowchart-based vision software is so easy to learn, anyone can use it. Design Assistant is an integrated development environment (IDE) where vision applications are created by constructing an intuitive flowchart instead of writing traditional program code. In addition to building a flowchart, the IDE enables users to directly design a graphical operator interface for the application. Since Design Assistant is hardware independent, you can choose any computer with GigE Vision® or USB3 Vision™ cameras and get the processing power you need. This field proven software is also a perfect match for the Matrox 4Sight GPM vision system or the Matrox Iris GT smart camera. Design Assistant gives you the freedom to choose the ideal platform for your next vision project.

Application design

Flowchart and operator interface design are done within the Matrox Design Assistant IDE running on the Matrox 4Sight GPM vision system or hosted on a computer running Microsoft® Windows®². A flowchart is put together using a step-by-step approach, where each step is taken from an existing toolbox and is configured interactively. The toolbox includes steps for image analysis and processing, communication, flow-control, and I/O. Outputs from one step, which can be images and/or alphanumeric results, are easily linked to the appropriate inputs of any other step. Decision making is performed using a conditional step, where the logical expression is described interactively. Results from image analysis and processing steps are immediately displayed to permit the quick tuning of parameters. A contextual guide provides assistance for every step in the flowchart. Flowchart legibility is maintained by grouping steps into sub-flowcharts.

In addition to flowchart design, Matrox Design Assistant enables the creation of a custom, web-based operator interface to the application through an integrated HTML visual editor. Users alter an existing template using a choice of annotations (graphics and text), inputs (edit boxes, control buttons and image markers) and outputs (original or derived results, and status indicators). A filmstrip view is also available to keep track of, and navigate to, previously analyzed images. The operator interface can be further customized using a third-party HTML editor.

Matrox Design Assistant can be used on a Matrox 4Sight GPM vision system or in emulation mode. The latter allows for the design and testing of a flowchart and the creation of an operator interface without requiring the Matrox vision system. Matrox Design Assistant's emulation mode is used to enable parallel project work, resulting in greater development efficiency.

Matrox Design Assistant Benefits

Easily and quickly solve machine vision applications without writing program code using an intuitive flowchart-based methodology

Choose the best platform for the job using a hardware-independent environment that supports any PC with any GigE Vision® or USB3 Vision™ camera

Also deploy the same project to a rugged and reliable Matrox vision system and smart camera

Tackle machine vision applications with utmost confidence using field-proven tools for analyzing, locating, measuring, reading, and verifying

Learn and use a single program for creating both the application logic and operator interface

Work with multiple cameras within the same project

Rely on a common underlying vision library for the same results with a Matrox smart camera, vision system or third-party computer

Maximize productivity by getting instant feedback on image analysis and processing operations

Get immediate pertinent assistance through an integrated contextual guide

Communicate actions and results to other automation and enterprise equipment through discrete Matrox I/Os, RS-232 and Ethernet (TCP/IP, EtherNet/IP™³, MODBUS®, PROFINET and native robot interfaces)

Maintain control and independence through the ability to create custom flowchart steps

Why a flowchart?

The flowchart is a universally accessible, recognized and understood method of describing the sequence of operations in a process. Manufacturing engineers and technicians in particular have all been exposed to the intuitive, logical and visual nature of the flowchart.

Matrox Design Assistant (cont.)

Create custom flowchart steps

Users have the ability to extend the capabilities of Matrox Design Assistant by way of the included Custom Step software development kit (SDK). The SDK, in combination with Microsoft® Visual Studio® 2010, enables the creation of custom flowchart steps using the C# programming language. These steps can implement proprietary image analysis and processing, as well as proprietary communication protocols. The SDK comes with numerous project samples to accelerate development.

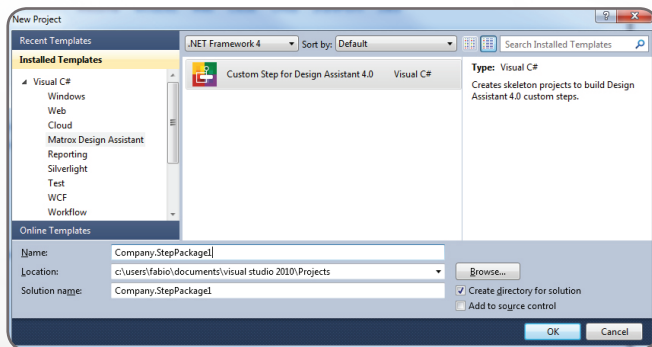

Custom Step SDK

Application deployment

Once development is complete, the project, with flowchart and operator interface, is deployed either locally or remotely. Local deployment is to the same computer or Matrox 4Sight GP vision system as was used for development. Remote deployment is to a different computer, including a Matrox 4Sight GPM vision system, or a Matrox smart camera.

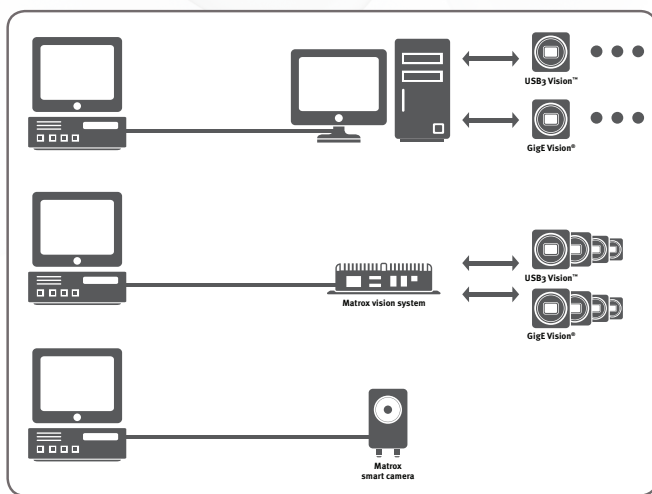

Samples, tutorials and training

Matrox Design Assistant includes numerous sample projects and video tutorials to help new developers quickly become productive. Matrox Imaging also offers an instructor-led training course held at Matrox headquarters and select locations worldwide. Refer to the support section at www.matrox.com/imaging for more information.

Matrox Design Assistant maintenance program

Matrox Design Assistant users who register their software are automatically enrolled in the maintenance program for one year. This maintenance program entitles registered users to technical support and free software upgrades from Matrox Imaging. Just before the expiration of the maintenance program, registered users will have the opportunity to extend the program for another year. For more information, refer to the Matrox Imaging Software Maintenance Programs brochure.

Integrated development environment (IDE)

Customizable developer interface

The Matrox Design Assistant user interface can be tailored by each developer. The workspace can be rearranged, even across multiple monitors, to suit individual preferences and further enhance productivity.

The screenshot displays the Matrox Design Assistant IDE interface, which is divided into several functional areas:

- Top Left:** A context-based list of actions for configuring the flowchart, such as 'Cut selected step(s)', 'Copy selected step(s)', 'Delete selected step(s)', 'Disable selected step(s)', 'Rename this step', and 'Comment this step'. Below this is a 'Try It' section with buttons for 'Reset', 'Run', 'Run to the selected step', 'Next step', and 'Rerun the selected step'. A 'Deploy' section includes a 'Deploy project' button.
- Top Center:** A flowchart titled 'MainFlowchart' showing a sequence of steps: 'CAM Camera', 'ALOR FindCroissant', a decision diamond 'IFBlobFound', 'NTE CheckBurn', 'MEAS CheckWidth', 'STA Status', and 'STOR Store'. A 'Loop' arrow connects the 'CheckWidth' step back to the 'FindCroissant' step.
- Top Right:** A 'Quick Access' panel providing context-sensitive help for the 'Stripe marker' tool. It includes a 'Properties' section and a 'Quick Access' section with numbered instructions for adjusting the search region and polarity.
- Center:** A 3D image of a croissant with a green rectangular search region overlaid on its surface.
- Bottom Left:** A 'Configuration' panel for the 'CheckWidth' step. It includes fields for 'Number' (set to 1), 'Minimum' (set to 1), 'Polarity' (set to 'Any'), 'First edge' (set to 'Any'), and 'Second edge' (set to 'Opposite'). There are also 'Region...', 'Filter...', 'Inclusion...', and 'Advanced...' buttons. A 'Constraints' section includes options for 'Fit' (Closest, Best, Advanced) and fields for 'Width', 'Spacing', and 'Maximum sub-position distance'.
- Bottom Center:** A 'Results' table showing the output of the 'CheckWidth' step. The table has columns for 'Marker', 'X', 'Y', 'Angle', 'Width', 'Polarity', and 'Contrast'. It shows results for 'Stripe (1)' and 'Occurrences'.
- Bottom Right:** A 'Step Log' panel showing the execution history of the flowchart, including 'FlowchartStart', 'Loop (4)', 'Camera (dsc_9924.jpg)', 'FindCroissant', 'IFBlobFound (True)', 'CheckBurn', and 'CheckWidth'.

Callouts from the surrounding text point to these specific features:

- 'Select the action to perform from a context-based list' points to the top-left action list.
- 'Conveniently switch between the flowchart and image, or operator views' points to the central workspace.
- 'Get quick access to context sensitive help' points to the top-right help panel.
- 'Configure each step without losing sight of flowchart and image' points to the bottom-left configuration panel.
- 'Instantly view results after each step' points to the bottom-center results table.
- 'Track and navigate the flowchart execution history without losing sight of the image' points to the bottom-right step log.

Operator view

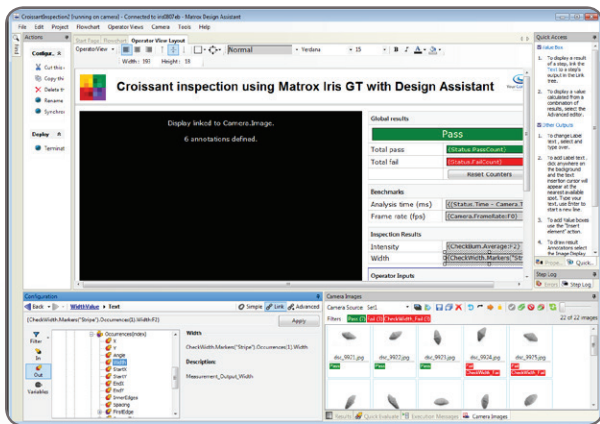

Design a customized operator view

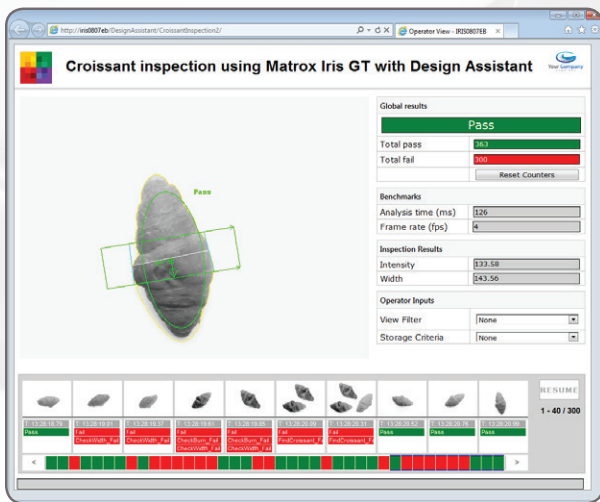

Resulting operator view as seen in a web browser

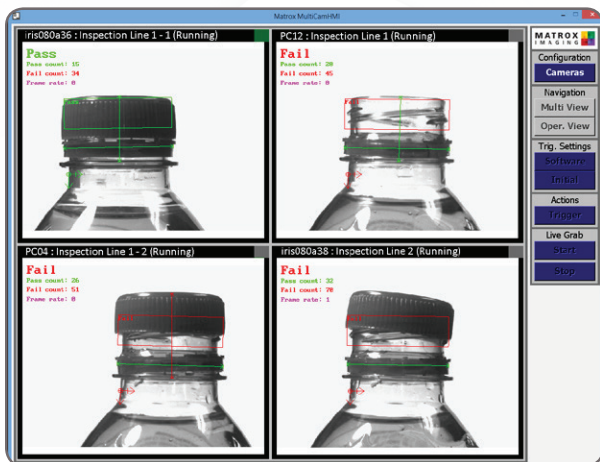

Multi-camera HMI application (Matrox MultiCamHMI)

Operator interface viewable anywhere

The web-based operator interface, or Operator View, can be accessed locally or remotely through a web browser⁴. Local viewing is done on the computer or Matrox 4Sight GPM vision system that is executing the project. Remote viewing is done from any computer, including dedicated HMI or touch-panel PCs.

A stand-alone HMI application can be created using Microsoft[®] Visual Studio[®] to run on the local or a remote computer as an alternative to the web-based operator interface. Sample HMI applications with source code are included like a multi-camera one to monitor or control projects running on different computers or Matrox smart cameras.

Security features

Access to specific Operator Views can be made to require user authentication (i.e., username and password) so only authorized personnel can modify key parameters of a running project. A project can be locked to a specific Matrox 4Sight GPM when deployed, preventing it from running on an unauthorized vision system. A project can also be encrypted during deployment to a vision system, ensuring that the project cannot be read or changed by unauthorized users. Projects locked to a vision system are automatically encrypted.

Vision tools

Image analysis and processing

Central to Matrox Design Assistant are flowchart steps for calibrating, enhancing and transforming images, locating objects, extracting and measuring features, reading character strings, and decoding and verifying identification marks. These steps are designed to provide optimum performance and reliability.

Pattern recognition

Matrox Design Assistant includes two steps for performing pattern recognition: Pattern Matching and Model Finder. These steps are primarily used to locate complex objects for guiding a gantry, stage or robot, or for directing subsequent measurement steps.

The Pattern Matching step finds a pattern by looking for a similar spatial distribution of intensity. The step employs a smart search strategy to quickly locate multiple patterns, including multiple occurrences, which are translated and slightly rotated. The step performs well when scene lighting changes uniformly, which is useful for dealing with attenuating illumination. A pattern can be trained manually or determined automatically for alignment. Search parameters can be manually adjusted and patterns can be manually edited to tailor performance.

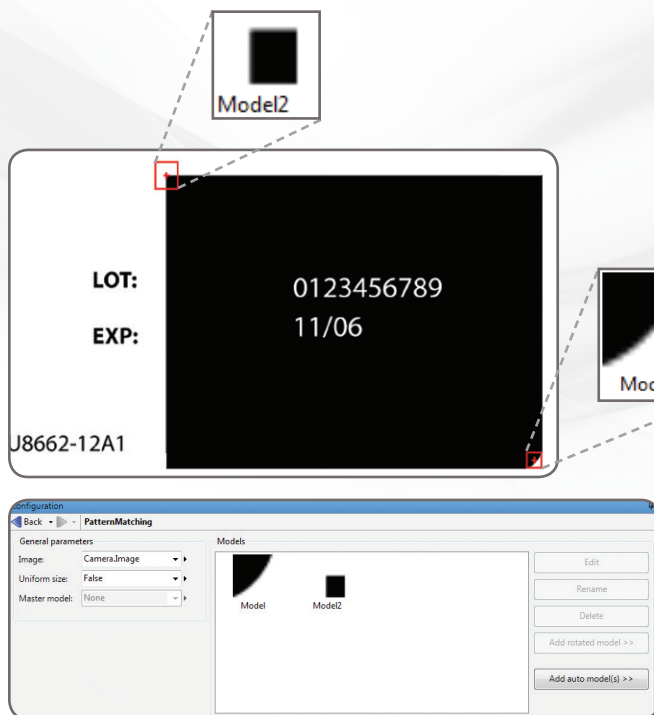

Pattern Matching

The Model Finder⁵ step employs an advanced technique to locate an object using geometric features (e.g., contours). The step finds multiple models, including multiple occurrences that are translated, rotated, and scaled. Model Finder locates an object that is partially missing and continues to perform when a scene is subject to uneven changes in illumination; relaxing lighting requirements. A model is manually trained from an image and search parameters can be manually adjusted and models can be manually edited to tailor performance.

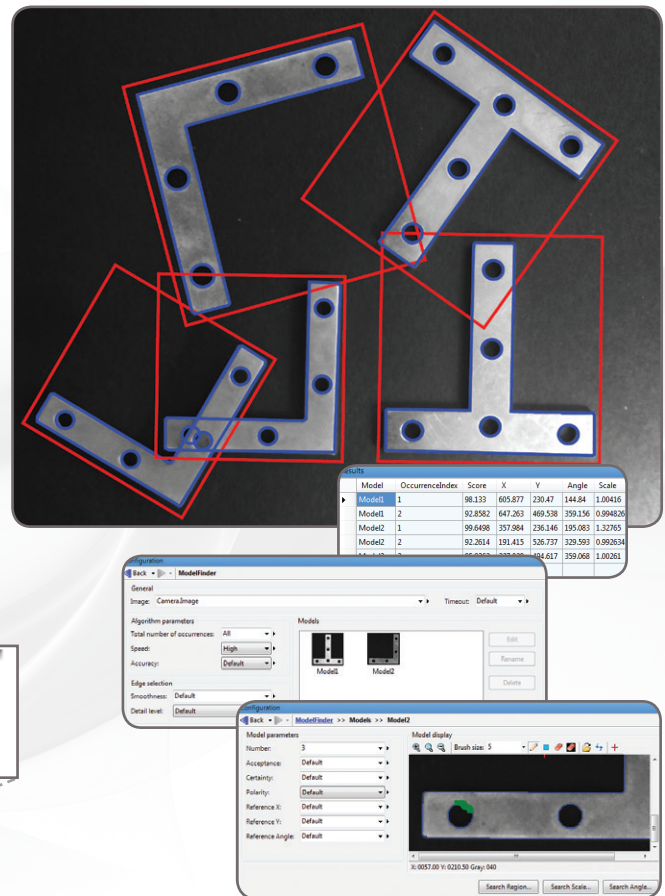

Model Finder

Vision tools (cont.)

Feature extraction and analysis

The Blob Analysis step is used to identify, count, locate and measure basic features and objects (i.e., blobs) to determine presence and position, and enable further inspection. The step works by segmenting images, where blobs are separated from the background and one another, before quickly identifying the blobs. Over 50 characteristics can be measured and these measurements can be used to eliminate or keep certain blobs.

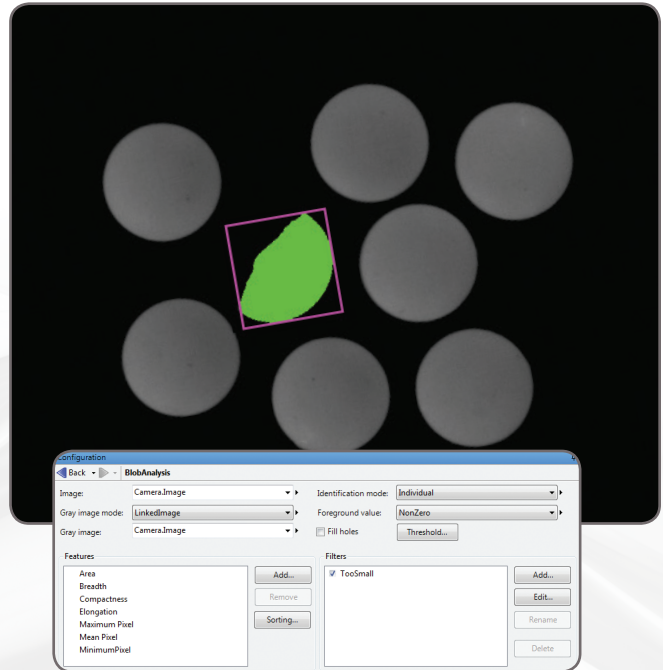

Blob Analysis

Vision tools (cont.)

1D and 2D measurements

Matrox Design Assistant includes three steps for measuring: Measurement, Bead Inspection and Metrology. These tools are predominantly used to assess manufacturing quality.

The Measurement step uses the projection of image intensity to very quickly locate and measure straight edges or stripes within a carefully defined rectangular region. The tool can make several 1D measurements on edges and stripes, as well as between edges or stripes.

The Bead Inspection step is for inspecting material that is applied as a continuous sinuous bead, such as adhesives and sealants, or its retaining channel. The step identifies discrepancies in length, placement and width, as well as discontinuities. The Bead Inspection step works by accepting a user-defined coarse path (as a list of points) on a reference bead and then automatically and optimally placing search boxes to form a template. The size and spacing of these search boxes can be modified to change the sampling resolution. The allowable bead width, offset, gap and overall acceptance measure can be adjusted to meet specific inspection criteria.

The Metrology step is intended for 2D geometric dimensioning and tolerancing applications. The step extracts edges within defined regions to best fit geometric features. It also supports the construction of geometric features derived from measured ones or defined mathematically. Geometric features include arcs, circles, points, and segments. The step validates tolerances based on the dimensions, positions, and shapes of geometric features. The step's effectiveness is maintained when subject to uneven changes in scene illumination, which relaxes lighting requirements. The expected measured and constructed geometric features, along with the tolerances, are kept together in a template, which is easily repositioned using the results of other locating steps.

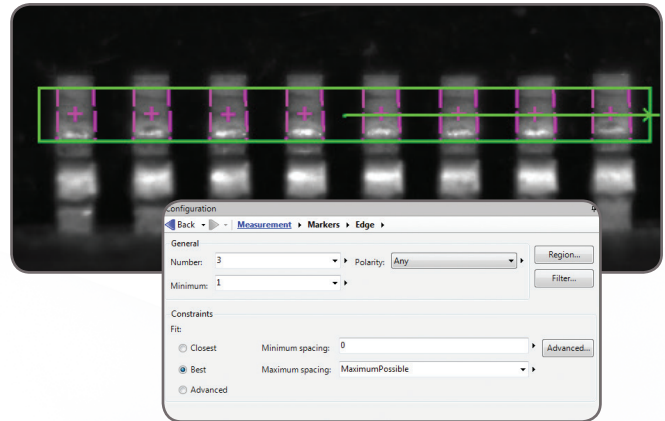

Measurement

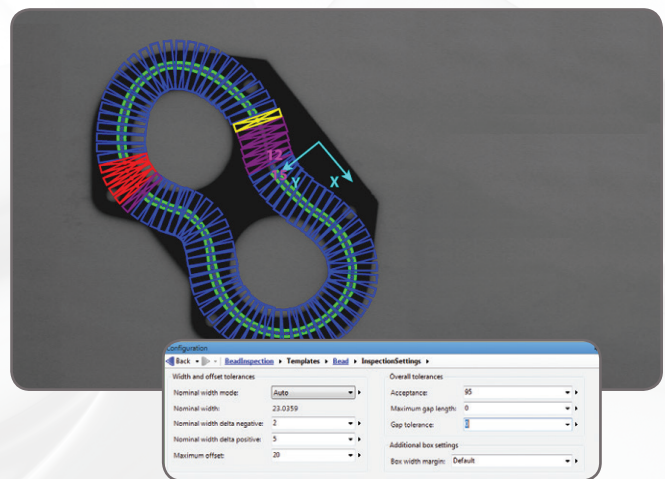

Bead Inspection

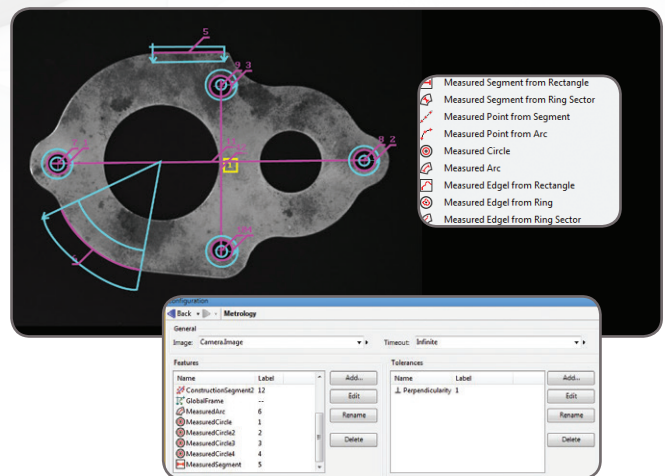

Metrology

Vision tools (cont.)

Color analysis

Matrox Design Assistant includes a set of tools to identify parts, products and items using color, assess quality from color, and isolate features using color.

The Color Matcher step determines the best matching color from a collection of samples for each region of interest within an image. A color sample can be specified either interactively from an image - with the ability to mask out undesired colors - or using numerical values. A color sample can be a single color or a distribution of colors (i.e., histogram). The Color Matching method and the interpretation of color differences can be manually adjusted to suit particular application requirements. The Color Matcher step can also match each image pixel to color samples to segment the image into appropriate elements for further analysis using other steps such as Blob Analysis.

The Image Processing step includes operations to calculate the color distance and perform color projection. The distance operation reveals the extent of color differences within and between images, while the projection operation enhances color to grayscale image conversion for analysis using other grayscale processing steps.

Character recognition

String Reader⁵ is a step for reading character strings that are engraved, etched, marked, printed, punched or stamped on surfaces. The step is based on a sophisticated OCR technique that uses geometric features to locate and read character strings where characters are well separated from the background and from one another. The step handles strings with a known or unknown number of evenly or proportionally spaced characters. It accommodates changes in character angle with respect to the string, aspect ratio, scale, and skew, as well as contrast reversal. Strings can be located across multiple lines and at a slight angle. The tool reads from multiple pre-defined or user-defined Latin-based fonts. In addition, character strings can be subject to user-defined grammar rules to further increase recognition rates.



Color Matcher



String Reader

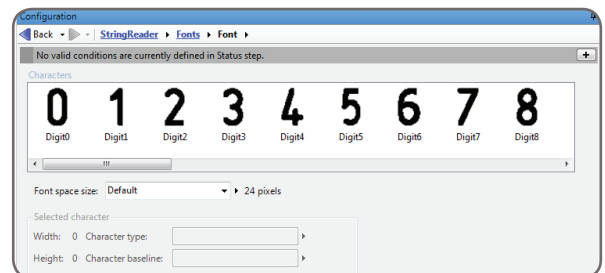

Vision tools (cont.)

1D and 2D code reading and verification

Code Reader is a step for locating and reading 1D, 2D and composite identification marks. The step handles rotated, scaled, and degraded codes in tough lighting conditions. The step can provide the orientation, position, and size of a code.

In addition, the Code Verify step verifies the quality of a code based on the ANSI/AIM and ISO/IEC grading standards.

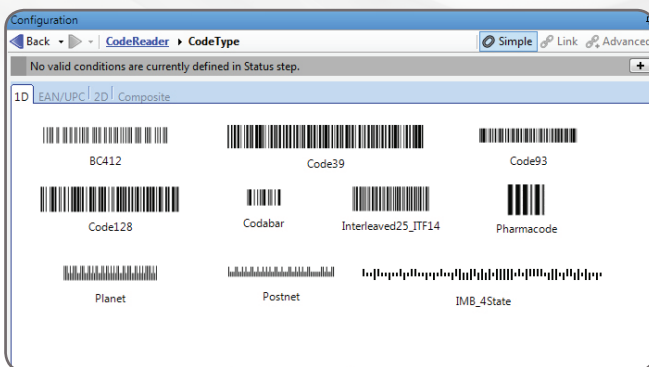
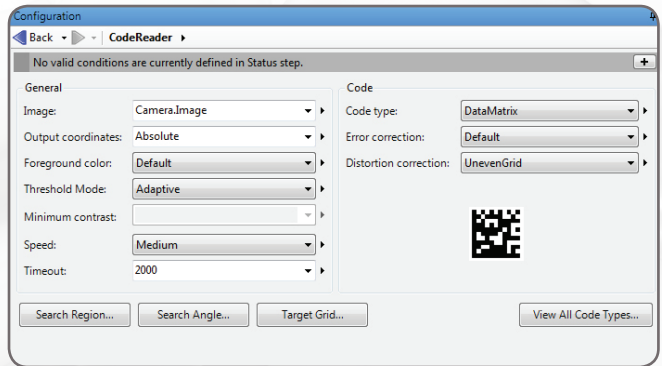
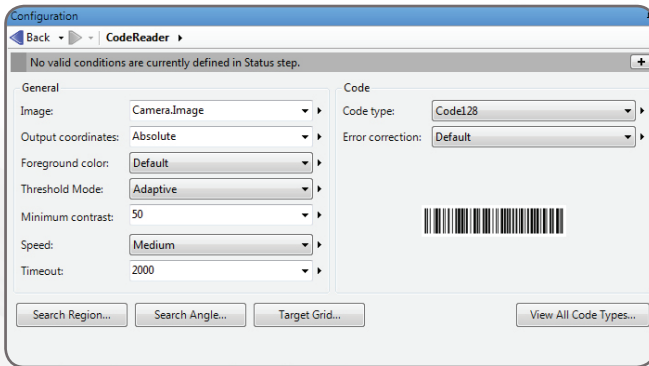
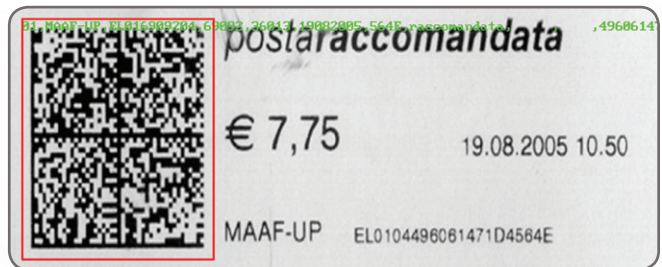

Code Reader (1D)

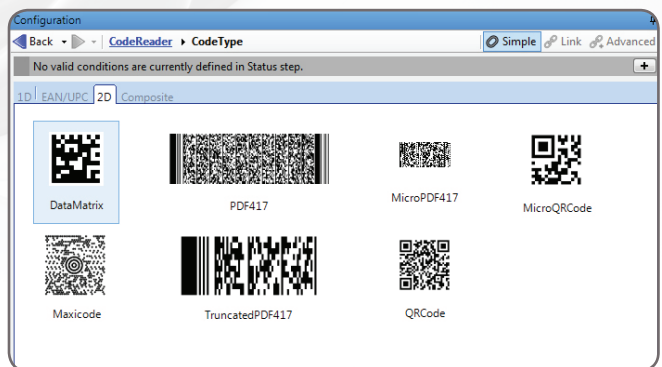

Code Reader (2D)

Vision tools (cont.)

Calibration

Calibration is a routine requirement for machine vision. Matrox Design Assistant includes a 2D Calibration step to convert results (i.e., positions and measurements) from pixel to real-world units and vice-versa. The tool can compensate results and even an image itself for camera lens and perspective distortions. Calibration is achieved using an image of a grid or just a list of known points and is performed through a utility project accessed from the Matrox Design Assistant configuration portal.

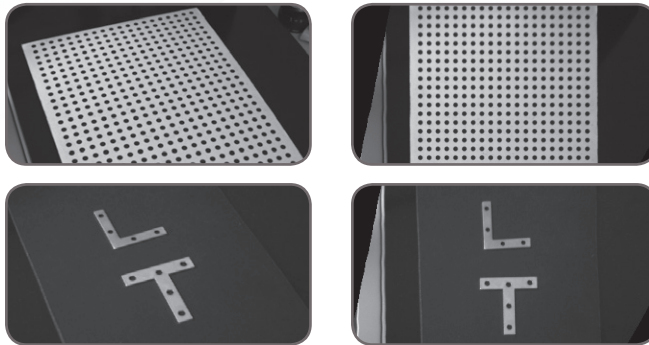
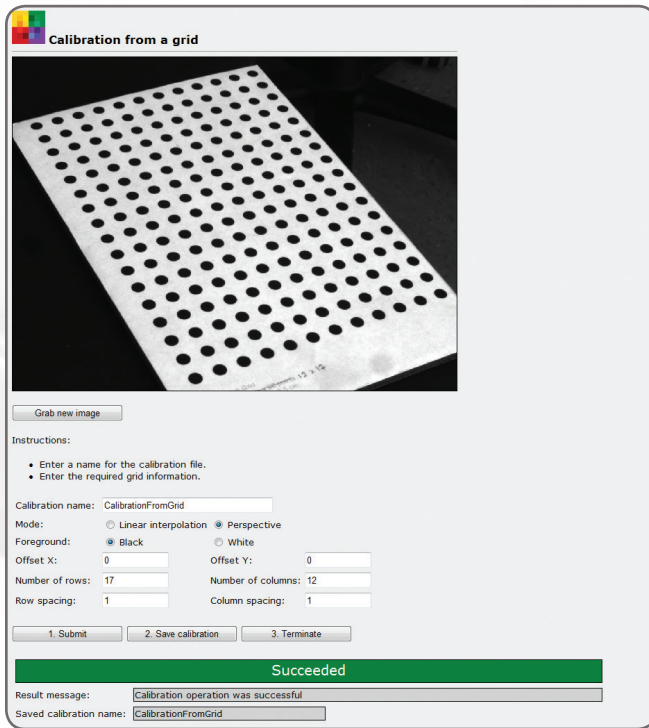

Calibration

Basic image processing

Matrox Design Assistant includes the Image Processing step for enhancing and transforming images in preparation for subsequent analysis. Supported operations include arithmetic, color space conversions, color distance and projection (refer to Color analysis section for details), filtering, geometric transformations, logic, LUT mapping, morphology and thresholding.

Matrox Design Assistant also includes Edge Locator and Intensity Checker. Edge Locator finds objects by locating straight edges and Intensity Checker is used to analyze an object using image intensity.

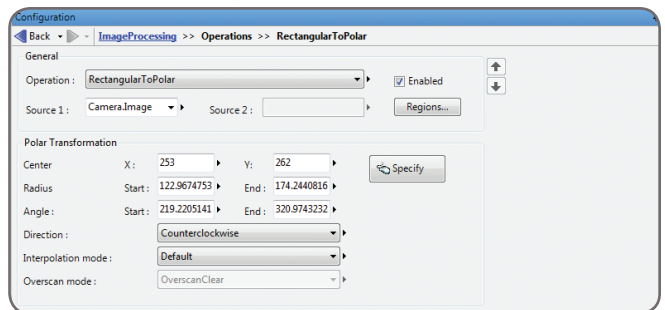
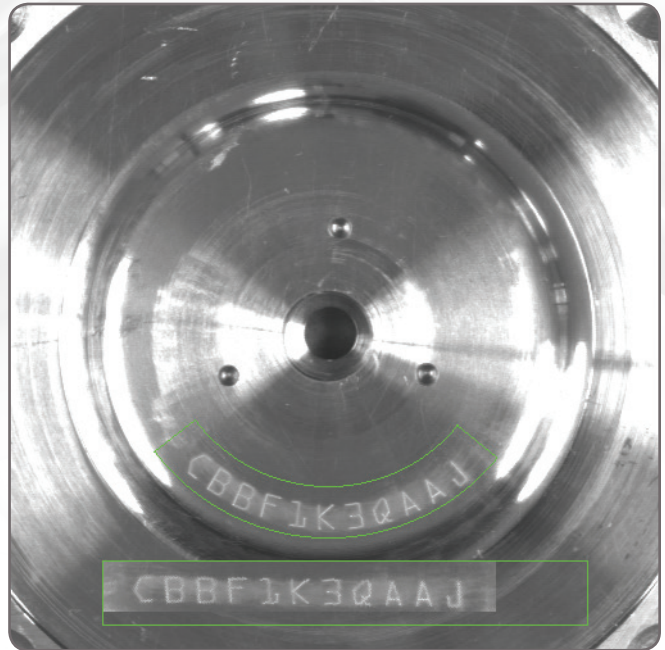
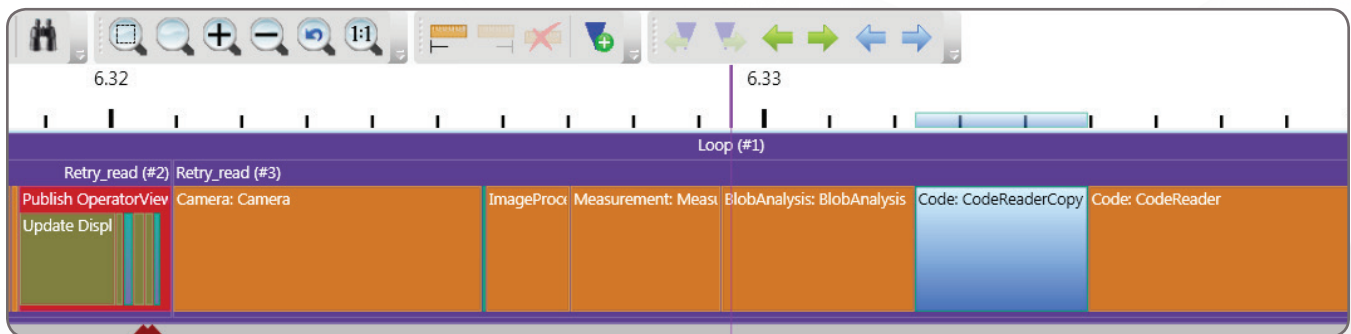

Image Processing

Utilities

Matrox Profiler

Matrox Design Assistant includes Matrox Profiler, a separate utility to post-analyze the execution of a vision project for performance bottlenecks and timing issues. It presents the flowchart step executed over time on a navigable timeline. Matrox Profiler permits searching for and selecting specific steps and their execution times for analysis.



Matrox Profiler

Matrox Capture Assistant

Matrox Capture Assistant is another separate utility included with Matrox Design Assistant to verify the connection to one or more GigE Vision® cameras. It allows for simple testing of video acquisition, obtains GigE Vision® device information, collects acquisition statistics and provides access to acquisition (GenICam™) properties. Matrox Capture Assistant can also adjust GigE Vision® driver settings and provide the means to troubleshoot connectivity issues.

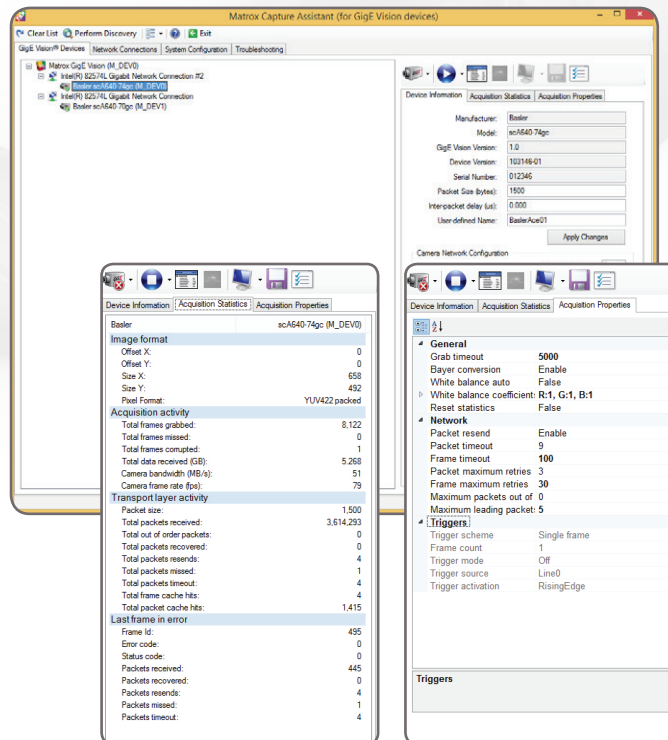

Matrox Capture Assistant

Connectivity

Connect to devices and networks

Matrox 4Sight GpM features four Power-over-Ethernet (PoE) Gigabit Ethernet ports for connecting to GigE Vision® cameras and four USB 3.0 ports for connecting to USB3 Vision™ cameras. Additionally, two more Gigabit Ethernet ports allow for direct connection to factory-floor and enterprise networks. Communication over these networks is configured through Matrox Design Assistant and can employ the TCP/IP as well as the EtherNet/IP™, MODBUS® over TCP/IP and PROFINET protocols, enabling interaction with automation controllers.

Direct communication can be established with select robot controllers⁶ for 2D vision-guided robotic applications. Matrox 4Sight GpM can also be configured to directly interact with automation devices through two RS232/RS485 serial interfaces as well as 16 industrial real-time digital I/Os (eight inputs and eight outputs). These I/Os have dedicated hardware to reliably count time intervals and pulses from rotary encoders.

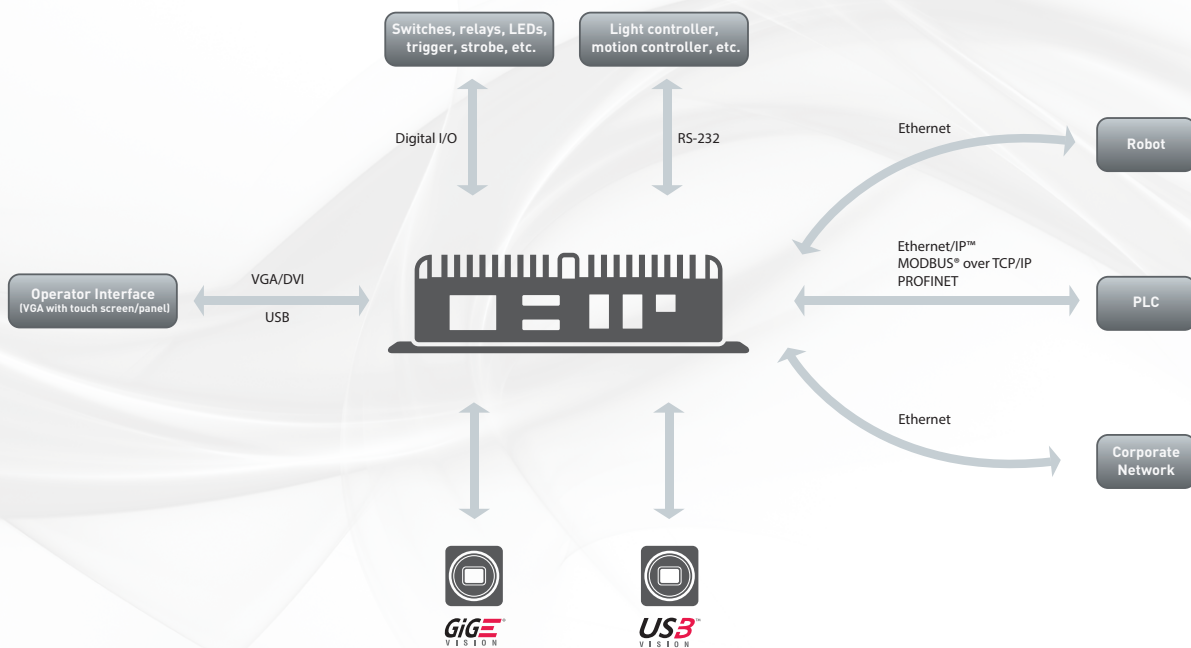

Matrox 4Sight GPM

Matrox 4Sight GPM (Ivy Bridge) block diagram

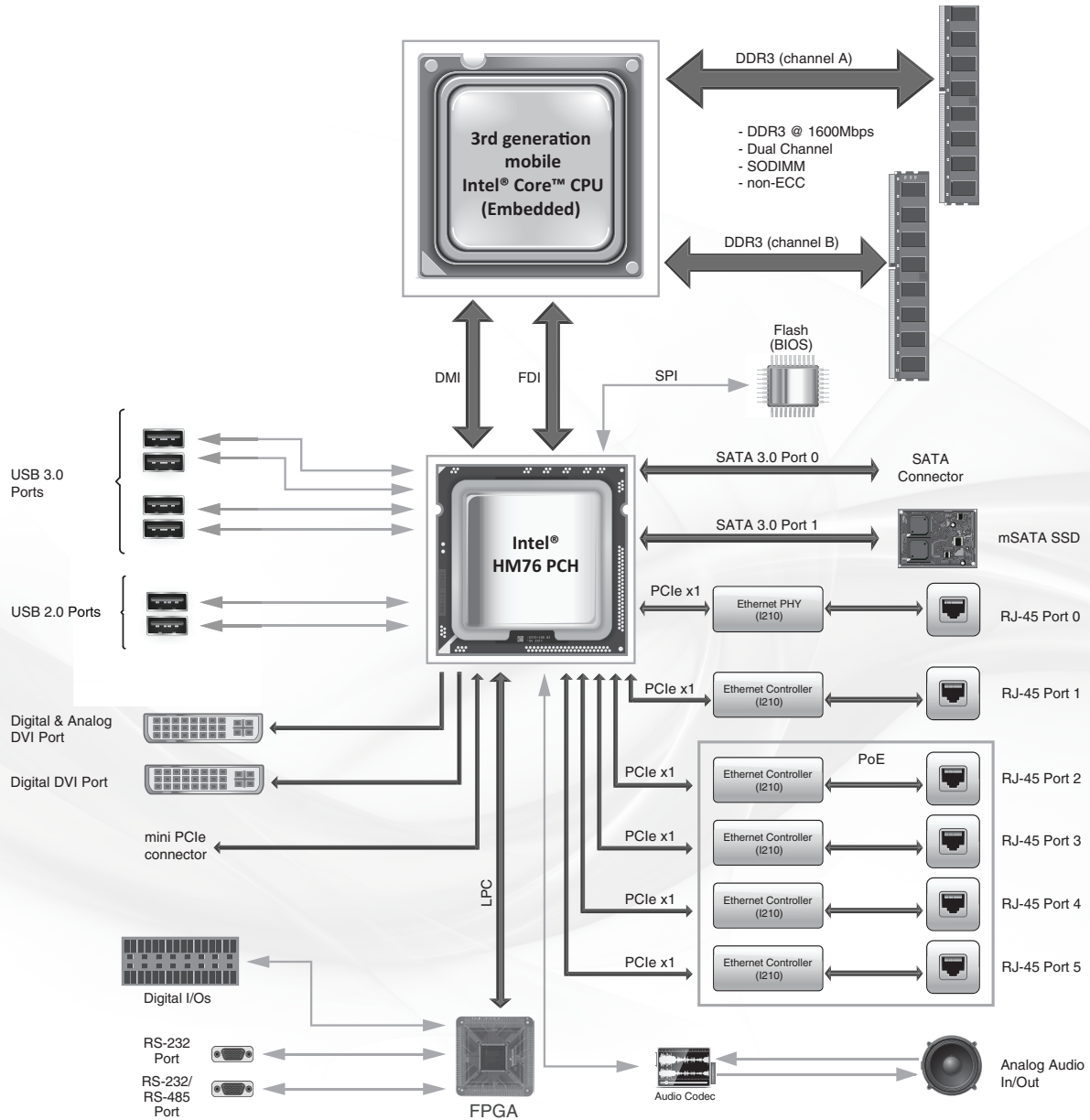

Matrox 4Sight GPM

4Sight GPM (Bay Trail) block diagram

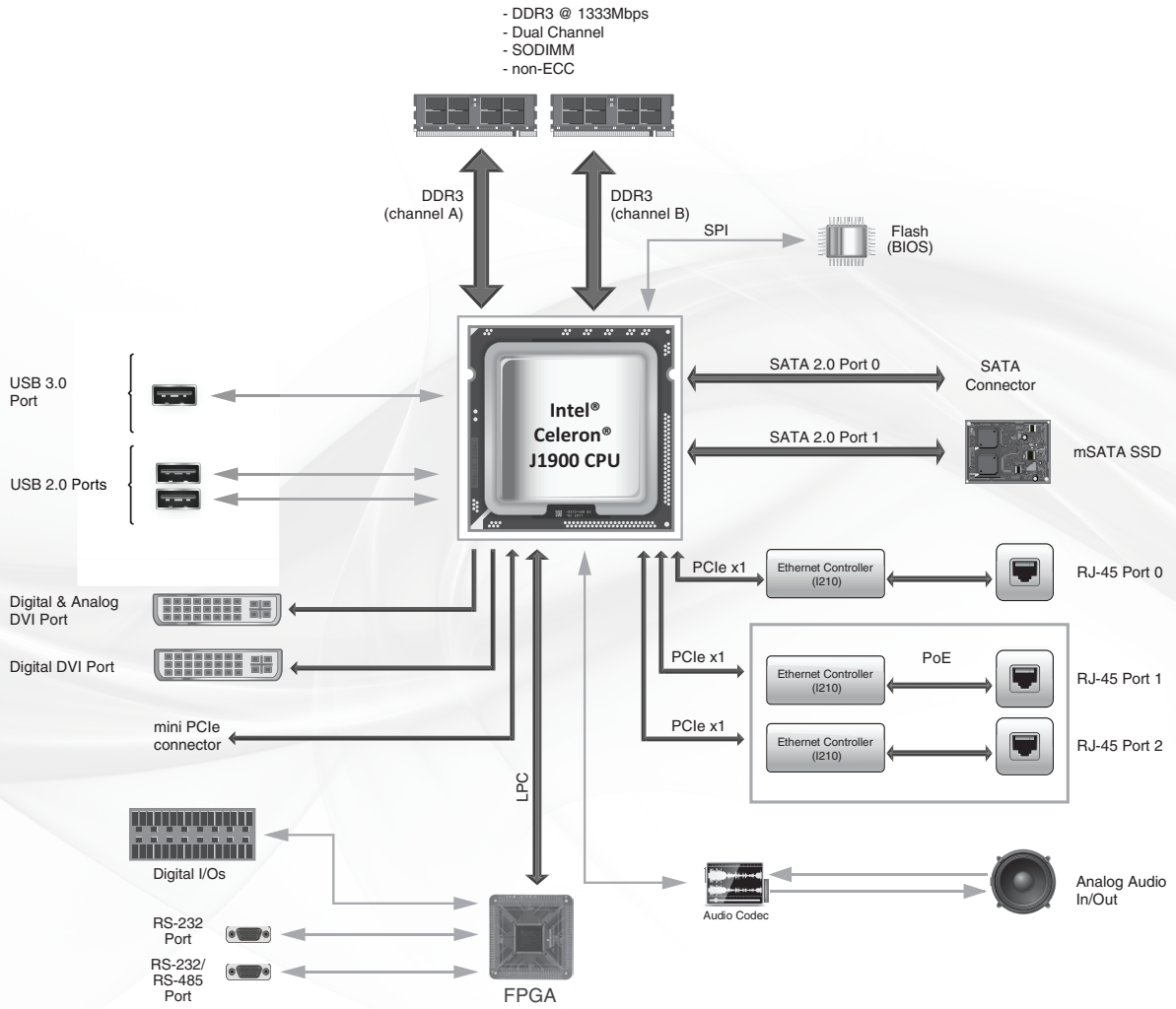

Matrox 4Sight GPM (cont.)

Matrox 4Sight GPM front and back

Matrox 4Sight GPM (Ivy Bridge)

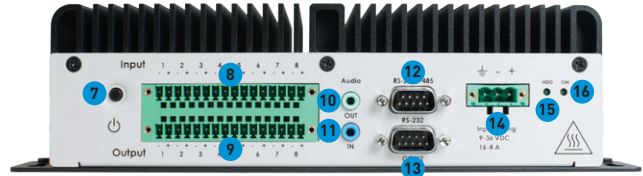
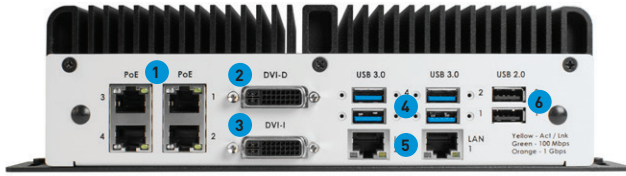

- | | | | | |
|-----------------------|------------------|--------------------|----------------------|------------------|
| 1. GbE ports with PoE | 4. USB 3.0 ports | 7. Power button | 11. Audio in | 14. Power input |
| 2. DVI-D output | 5. GbE ports | 8. Digital inputs | 12. RS232/RS485 port | 15. HDD LED |
| 3. DVI-I output | 6. USB 2.0 ports | 9. Digital outputs | 13. RS232 port | 16. Power on LED |
| | | 10. Audio out | | |

Matrox 4Sight GPM (Bay Trail)

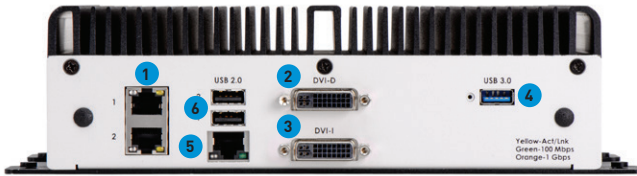

Matrox 4Sight GPM chassis

Matrox 4Sight GPM (Ivy Bridge)



Front



Matrox 4Sight GPM (Bay Trail)

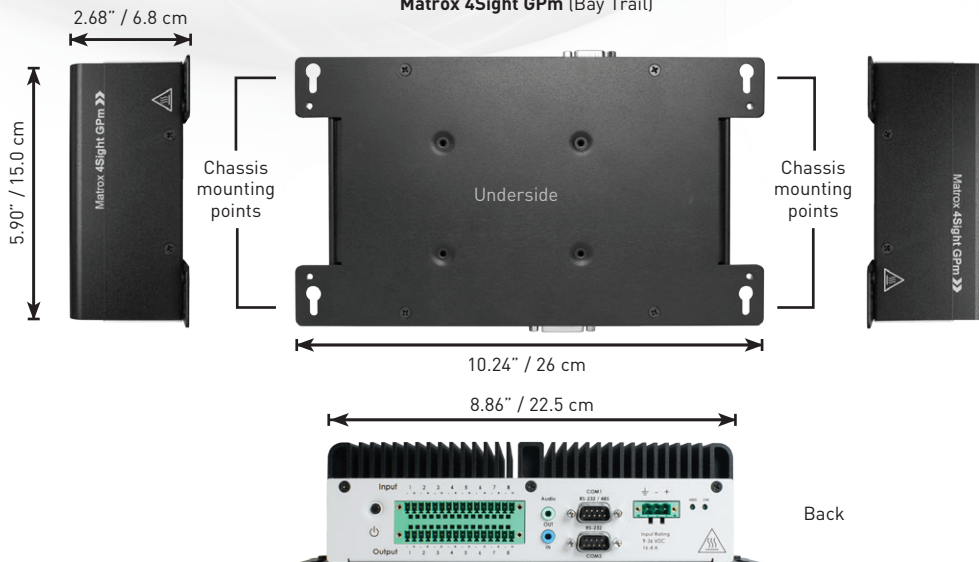

Matrox 4Sight GPM (cont.)

Specifications

System (Ivy Bridge) / (Bay Trail)

- Intel® HM76 Platform Controller Hub (PCH) / NA
- two (2) 204-pin DDR3-1600/1333 SODIMM slots (dual channel)
- dual head graphics support
 - one (1) DVI display output
DVI-D 1.0 compliant
up to 1920 x 1200 @ 60Hz
 - one (1) DVI-I display output
up to 1920 x 1200 @ 60Hz digital
up to 2048 x 1536 @ 75Hz / 60Hz analog
- six (6) / three (3) Gigabit Ethernet ports (10/100/1000)
 - four (4) / two (2) GbE ports with PoE
(up to 15.4 watts per port)
 - two (2) / one (1) standard GbE ports
- four (4) / one (1) USB 3.0 ports
- two (2) USB 2.0 ports
- one (1) SATA port (internal)
- one (1) mSATA connector
(used by supplied 64/32 GB mSATA MLC SSD)
- one (1) miniPCIe connector (internal)
- one (1) 24-bit stereo audio input and 24-bit stereo output
- one (1) RS-232 port
- one (1) RS-232/RS485 port
- sixteen (16) digital I/Os
 - eight (8) inputs
up to 24 V
 - eight (8) outputs (open collector)
100mA max. @ 24 VDC
- 64GB / 32 GB mSATA SSD
- power input: 10 to 32 VDC (nominal 24VDC @ 4.2Amps)
- fanless enclosure
- dimensions
 - length: 22.5 cm (8.86")
 - width: 15.0 cm (5.90")
 - height: 6.8 cm (2.68")
- mounting
 - four mounting slots

Configuration (Bay Trail)

- Intel® Celeron® J1900
 - Quad core
 - 2.0 GHz - 2.4 GHz
 - 2MB cache
 - Intel® HD Graphics (688 MHz - 854 MHz)
- 4 GB Dual Channel DDR3-1333

Specifications (cont.)

Configurations (Ivy Bridge)

- Intel® Core™ i7-3517UE
 - Dual core with hyperthreading
 - 1.7 GHz - 2.8 GHz
 - 4 MB cache
 - Intel® HD Graphics 4000 (350 MHz - 1 GHz)
- Intel® Core™ i3-3217UE
 - Dual core with hyperthreading
 - 1.6 GHz
 - 3MB cache
 - Intel® HD Graphics 4000 (350 MHz - 900 MHz)
- Intel® Celeron® 1047UE
 - Dual core
 - 1.4GHz
 - 2 MB cache
 - Intel® HD Graphics (350MHz - 900 MHz)
- 4 GB Dual Channel DDR3-1600
- 8 GB Dual Channel DDR3-1600

Environmental Information

- 0° C (32° F) to 50° C (122° F) operating temperature
- -40° C (-40° F) to 85° C (185° F) storage temperature
- up to 90% (non-condensing) relative humidity

Certifications

- FCC part 15 class A
- CE Class A (ITE)
- CSA certified to CSA60950 and UL60950
- RoHS-compliant

Order

Hardware

Part number	Description
4GPMJM4DA* NEW	Matrox 4Sight Gpm integrated unit with Intel® Celeron® J1900, 4GB DDR3 RAM, 32 GB mSATA MLC SSD, Microsoft® Windows® Embedded Standard 7 (32 -bit or 64 -bit) ⁷
4GPMC4DA*	Matrox 4Sight Gpm integrated unit with Intel® Celeron® 1047UE, 4GB DDR3 RAM, 64GB mSATA MLC SSD, Microsoft® Windows® Embedded Standard 7 (32 -bit or 64 -bit) ⁷ . Includes Matrox Design Assistant.
4GPMI3M8DA*	Matrox 4Sight Gpm integrated unit with Intel® Core™ i3-3217UE, 8GB DDR3 RAM, 64GB mSATA MLC SSD, Microsoft® Windows® Embedded Standard 7 (32 -bit or 64 -bit) ⁷ . Includes Matrox Design Assistant.
4GPMI7M8DA*	Matrox 4Sight Gpm integrated unit with Intel® Core™ i7-3517UE, 8GB DDR3 RAM, 64GB mSATA MLC SSD, Microsoft® Windows® Embedded Standard 7 (32 -bit or 64 -bit) ⁷ . Includes Matrox Design Assistant.
4GPMPS*	100W AC/DC power adapter (90-264 VAC input/24 VDC output) for Matrox 4Sight Gpm.

Endnotes:

- This product may be protected by one or more patents. See www.matrox.com/patents.
- 32/64-bit Microsoft® Windows® 7 with SP1 and Windows® 8(.1)
- Certification pending.
- Internet Explorer® 8 or higher.
- Requires a supplemental license.
- Currently supports ABB IRC5, Epson RC450+ / RC550+ and Fanuc LR Mate 200iC / LR Mate 200iD controllers.
- With support for multiple languages:
Only one language version can be used at any given time.
Une seule version de langue peut être utilisée à la fois.
Nur eine Sprachversion kann zu jeder gegebenen Zeit verwendet werden.
Solo una versione di ogni lingua puo' essere utilizzata allo stesso tempo.
Solo puede ser utilizada la versión de un idioma a la vez.
いかなる時でも一言語毎の使用のみが、可能になります。
한 가지 언어로만 제공되며 언제든지 사용이 가능하다
两种以上的语言版本不可以同时使用

Software

Matrox Design Assistant

Matrox 4Sight Gpm with Matrox Design Assistant comes fully pre-loaded with the latter and includes a Matrox Design Assistant Maintenance registration number. Matrox 4Sight Gpm with Matrox Design Assistant is pre-licensed for the Blob Analysis, Bead Inspection, Calibration, Code Reader, Color Analysis, Edge Locator (not Edge Finder), Image Processing, Intensity Checker, Metrology, Pattern Matching, GigE Vision®, USB3 Vision™, I/O and other communication features. Additional features like Model Finder and/or String Reader require the installation of an additional license (see MIL datasheet – MIL 10 Run-Time Licenses section).

Matrox Design Assistant Maintenance Program

Part number	Description
-------------	-------------

Included in the original purchase price of the Matrox 4Sight Gpm with Matrox Design Assistant, it entitles registered users to one year of technical support and access to updates.

DAMAIN	One-year extension to Matrox Design Assistant maintenance program per developer.
--------	--

Note: 75% discount for DAMAINTENANCE if purchased with MIL Maintenance (i.e., MILMAINTENANCE) for the same user. 50% educational discount for DA4MAINT with proof of institutional affiliation. Discounts cannot be combined.

Matrox Design Assistant Training

Part number	Description
-------------	-------------

DA TRAIN	"Matrox Design Assistant environment" training. 2+ day instructor-led training. Visit www.matroximaging.com/training for more information.
----------	--



About Matrox Imaging

Founded in 1976, Matrox is a privately held company based in Montreal, Canada. Graphics, Video and Imaging divisions provide leading component-level solutions for commercial graphics, professional video editing and industrial imaging respectively. Each division leverages the others' expertise and industry relations to provide innovative timely products.

Matrox Imaging is an established and trusted supplier to top OEMs and integrators involved in the manufacturing, medical diagnostic and security industries. The components delivered consist of cameras, interface boards and processing platforms, all designed to provide optimum price-performance within a common software environment.

Corporate headquarters:

Matrox Electronic Systems Ltd.

1055 St. Regis Blvd. Dorval, Quebec H9P 2T4 Canada Tel: +1 (514) 685-2630 Fax: +1 (514) 822-6273

For more information, please call: 1-800-804-6243 (toll free in North America) or (514) 822-6020 or e-mail: imaging.info@matrox.com or <http://www.matrox.com/imaging>

matrox®

The use of the terms industrial or factory-floor do not indicate compliance to any specific industrial standards. All trademarks by their respective owners are hereby acknowledged. Matrox Electronic Systems, Ltd. reserves the right to make changes in specifications at any time and without notice. The information furnished by Matrox Electronic Systems, Ltd. is believed to be accurate and reliable. However, no responsibility license is granted under any patents or patent rights of Matrox Electronic Systems, Ltd. Windows, Microsoft, Internet Explorer and Visual Studio are trademarks of Microsoft Corporation. © Matrox Electronic Systems, 2014. Printed in Canada, 2015-09-15 **51E-5494-B**